



04/2006 -

**CITROEN**

JUMPER II, III  
(L1, L2, L3)

**FIAT**

DUCATO III  
(L1, L2, L3)

**PEUGEOT**

BOXER III  
(L1, L2, L3)

Cat. No. C/025

e20

e20\*94/20\*0784\*00

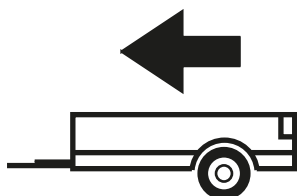

3 100kg

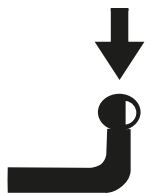

120kg

**D** = 15,09kN

**D (kN) =**



MAX kg

x

MAX kg

x 0,00981



MAX kg

+

MAX kg



**IMIOLA HAK-POL**

96-111 KOWIESY, CHOJNATA 23A, POLAND

tel. +48 46 831 73 31, fax +48 831 74 29

e-mail: office@imiola.pl, www.imiola.pl

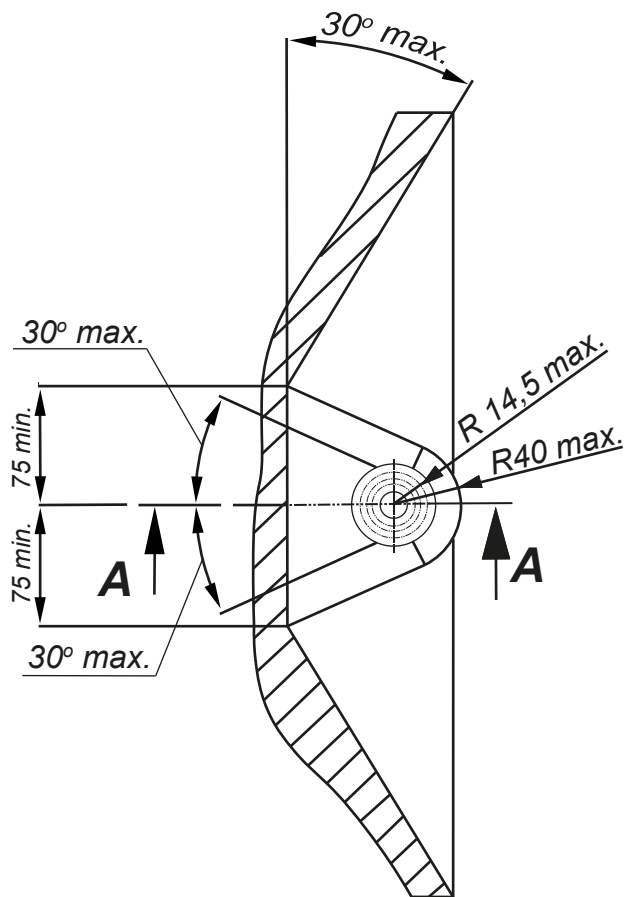

## PRZEKRÓJ A-A

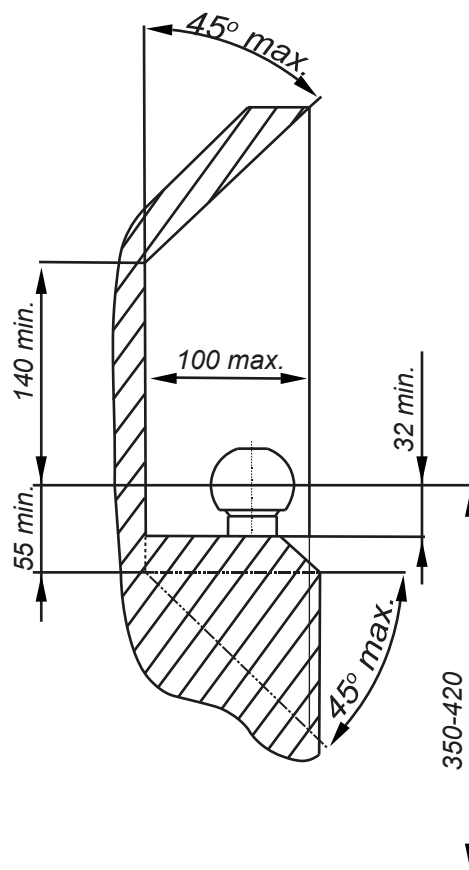

**PL** Należy zagwarantować przestrzeń swobodną według załącznika VII, rysunek 25a/b Regulaminu EKG ONZ 55.01 przy dopuszczalnym ciężarze całkowitym pojazdu.

**F** L'espace libre doit être garanti conformément à l'annexe VII, illustration de la réglementation 55.01 CE pour un poids total en charge autorisé du véhicule.

**GB** The clearance specified in appendix VII, diagram 25a/b of Regulation No. 55.01 UN EU must be guaranteed at laden weight of the vehicle.

**D** Der Freiraum nach Anhang VII, Abbildung 25a/b der Vorschriften 55.01 EG ist zu gew 25a/bahrleiten bei zulässigem Gesamtgewicht des Fahrzeuges.

### Moment skrecający dla śrub i nakrętek (8.8) Torque settings for nuts and bolts (8.8)

M8	25Nm
M10	55Nm
M12	<b>85Nm</b>
M14	135Nm
M16	195Nm



Nakrętka M10 ; Nut  
Podkł. spręż. 10,2 ; Spring Washer  
Podkł. okr. Ø30x Ø10,5x 3 ; Plain Washer

Nakrętka M12 ; Nut  
Podkł. spręż. 12,2 ; Spring Washer  
Podkł. okr. Ø36x Ø13x 3 ; Plain Washer

Śruba M12x130-8.8 ; Bolt  
Podkł. okr. 13 ; Plain Washer

Śruba M12x180-8.8 ; Bolt  
Podkł. okr. 13 ; Plain Washer

Nakrętka M16 ; Nut  
Podkł. spręż. 16,3 ; Spring Washer  
Podkł. okr. 17 ; Plain Washer

Nakrętka M10 ; Nut  
Podkł. spręż. 10,2 ; Spring Washer  
Podkł. okr. Ø30x Ø10,5x 3 ; Plain Washer

Śruba M12x35-8.8 ; Bolt

Śruba M12x35-8.8 ; Bolt  
Podkł. spręż. 12,2 ; Spring Washer  
Podkł. okr. 13 ; Plain Washer

Śruba M10x35-8.8 ; Bolt  
Podkł. okr. 10,5 ; Plain Washer

Śruba M16x45-8.8 ; Bolt

Śruba M10x25-8.8 ; Bolt

Nakrętka M10 ; Nut  
Podkł. spręż. 10,2 ; Spring Washer  
Podkł. okr. Ø30x Ø10,5x 3 ; Plain Washer

Nakrętka M12 ; Nut  
Podkł. spręż. 12,2 ; Spring Washer  
Podkł. okr. 13 ; Plain Washer

Nakrętka M12 ; Nut  
Podkł. spręż. 12,2 ; Spring Washer  
Podkł. okr. Ø36x Ø13x 3 ; Plain Washer

Śruba M10x35-8.8 ; Bolt  
Podkł. okr. 10,5 ; Plain Washer

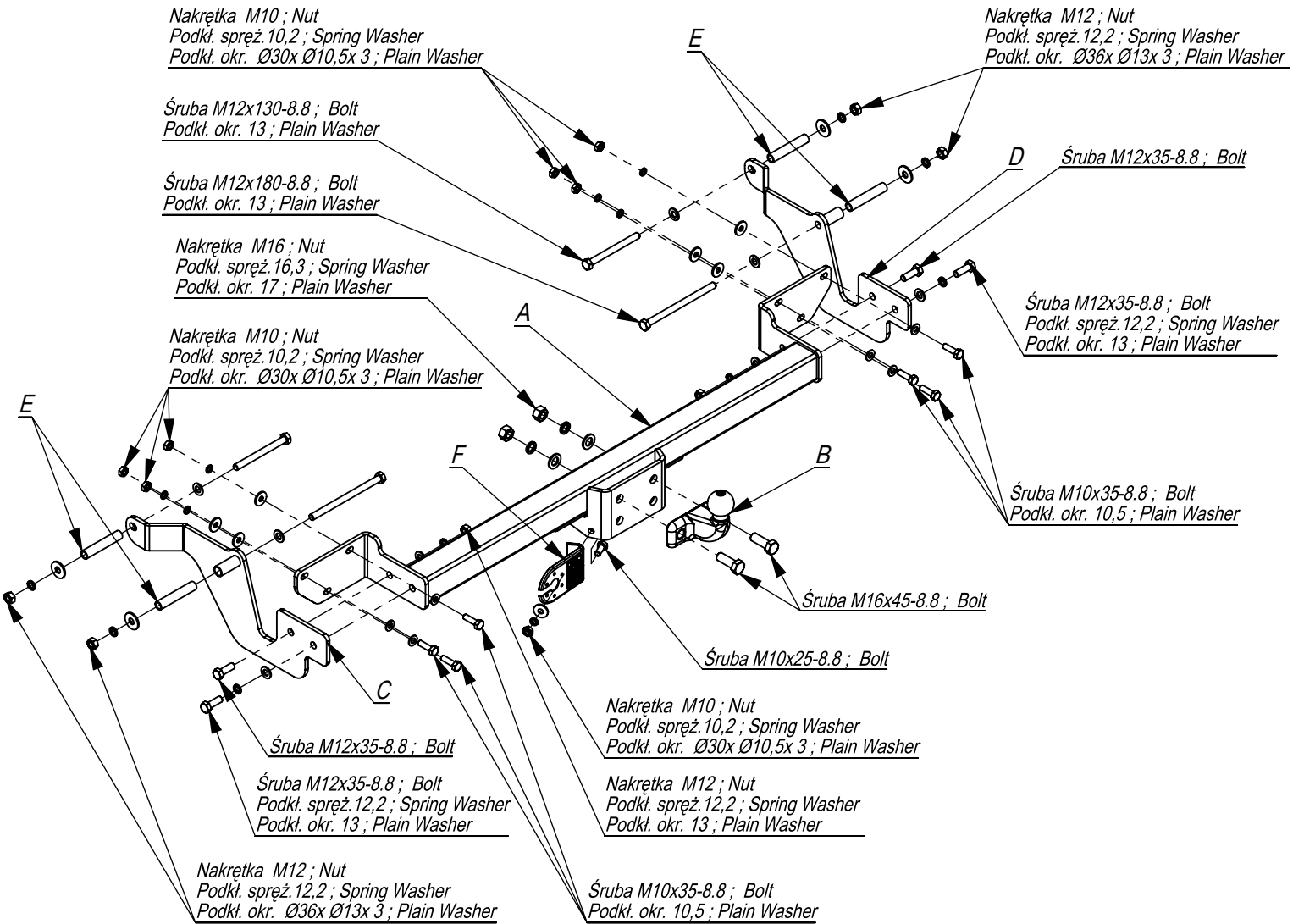

	A	x1		M16x45	2
	C	x1		M12x180	2
	E	x4		M12x130	2
	A	x1		M12x35	4
	C	x1		M10x35	6
	E	x4		M10x25	1
	A	x1		M16	2
	C	x1		M12	6
	E	x4		M10	7
	A	x1		Ø36xØ13x3	4
	C	x1		Ø30xØ10,5x3	7
	E	x4		17	2
	A	x1		13	8
	C	x1		10,5	6
	E	x4		16,3	2
	A	x1		12,2	8
	C	x1		10,2	7

