



## MERCEDES VIANO MERCEDES VITO

08/2003 - 08/2014  
09/2003 - 08/2014

Cat. No. M/020

e20

e20\*94/20\*0185\*00

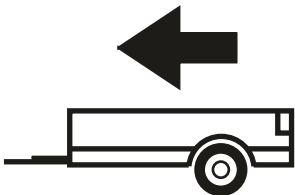

2500kg

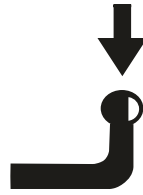

100kg

**D** = 13,25kN

**D (kN) =**



MAX kg

x

MAX kg

x 0,00981



MAX kg

+

MAX kg

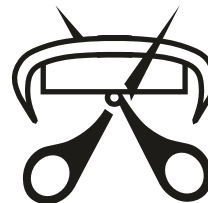

IMIOLA HAK-POL

96-111 KOWIESY, CHOJNATA 23A, POLAND

Tel. + 48 46 831 73 31, fax +48 831 74 29

e-mail: office@imiola.pl, www.imiola.pl

## PRZEKRÓJ A-A

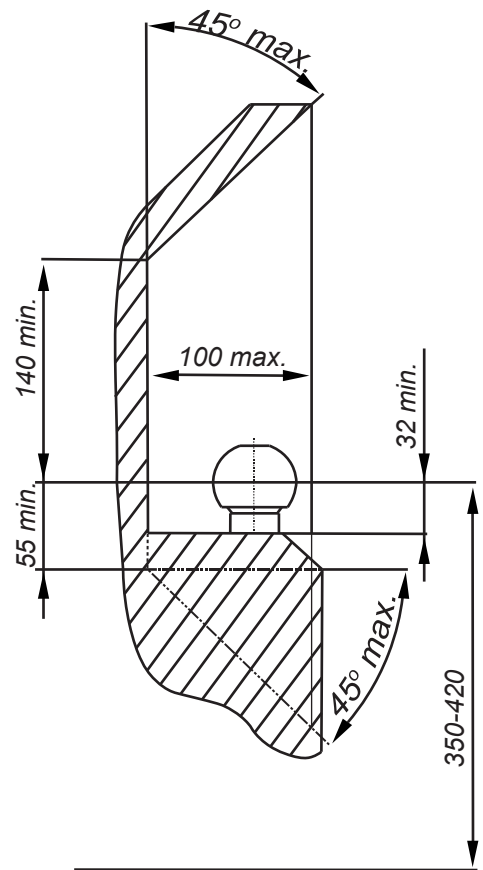
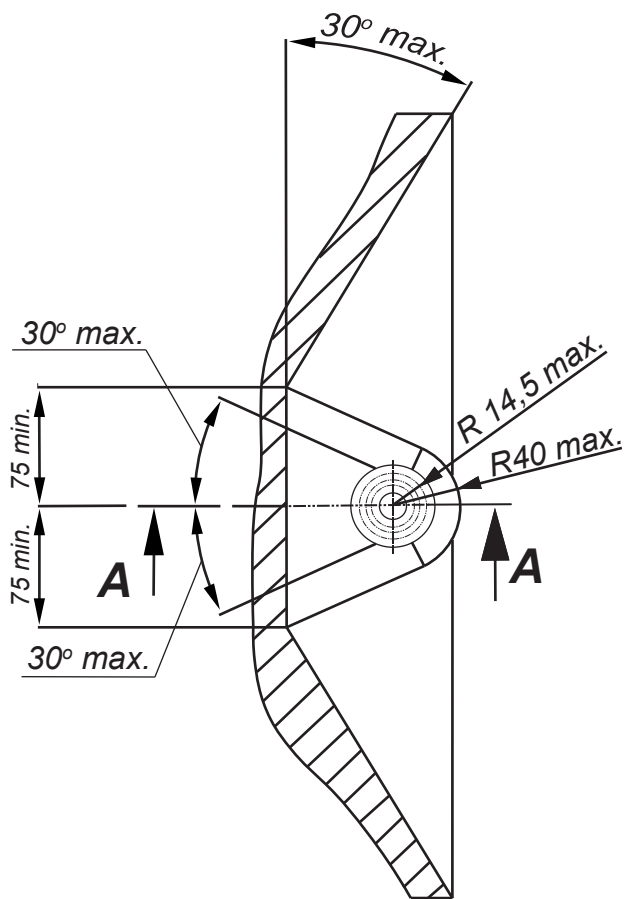

**PL** Należy zagwarantować przestrzeń swobodną według załącznika VII, rysunek 25a/b Regulaminu EKG ONZ 55.01 przy dopuszczalnym ciężarze całkowitym pojazdu.

**F** L'espace libre doit être garanti conformément à l'annexe VII, illustration de la réglementation 55.01 CE pour un poids total en charge autorisé du véhicule.

**GB** The clearance specified in appendix VII, diagram 25a/b of Regulation No. 55.01 UN EU must be guaranteed at laden weight of the vehicle.

**D** Der Freiraum nach Anhang VII, Abbildung 25a/b der Vorschriften 55.01 EG ist zu gew 25a/b abzuwehren bei zulässigem Gesamtgewicht des Fahrzeuges.

Moment skręcący dla śrub i nakrętek (8.8) Torque settings for nuts and bolts (8.8)	
M8	25Nm
M10	55Nm
M12	85Nm
M14	135Nm
M16	195Nm

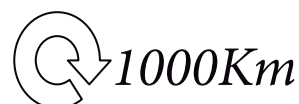

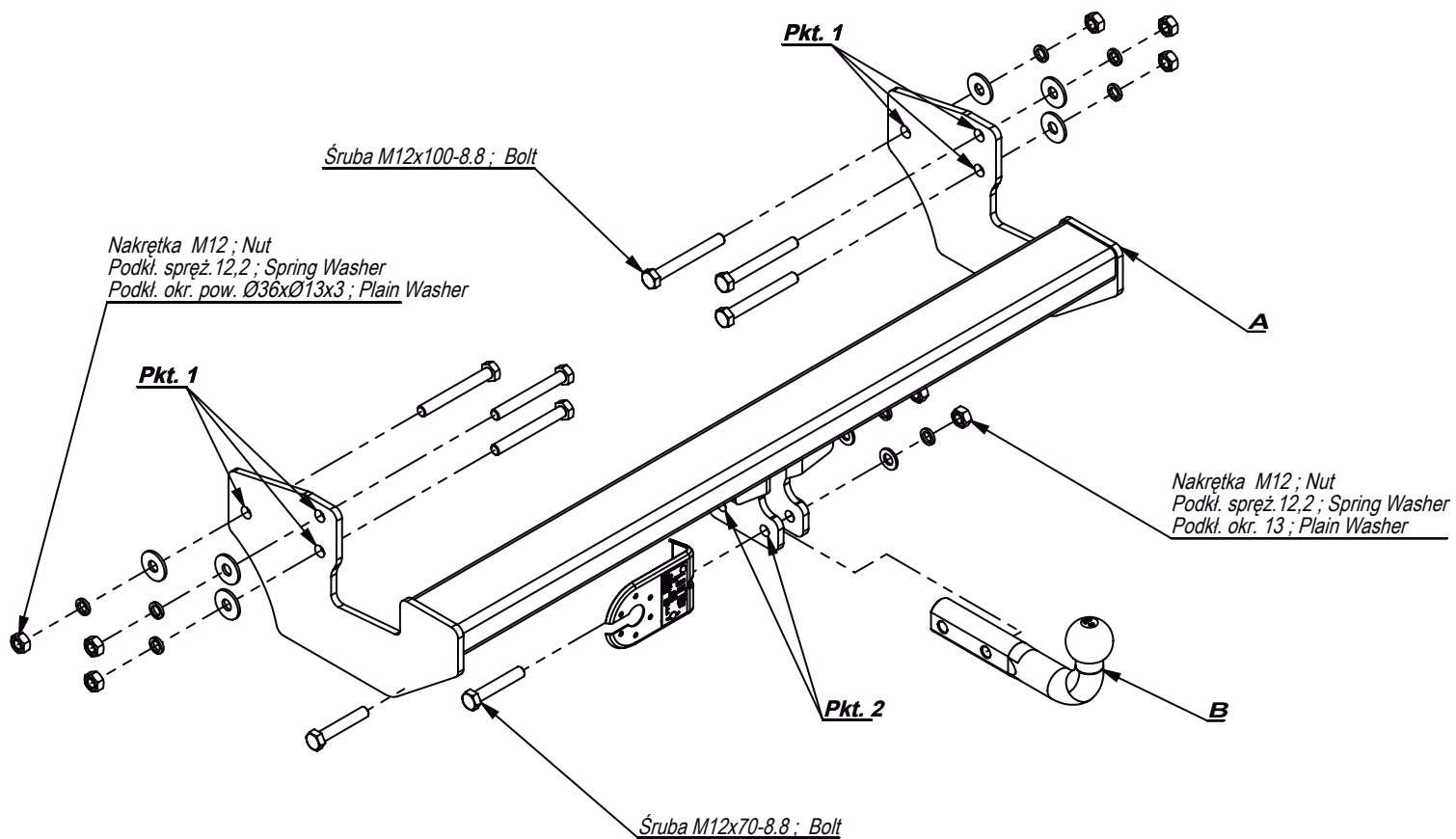

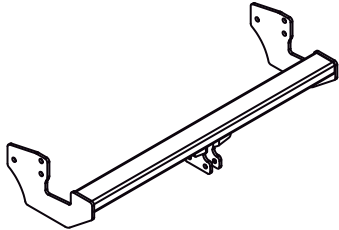
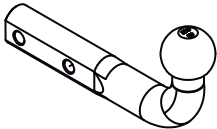
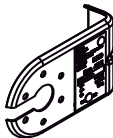
	A
	x1
	B
	x1
	C
	x1

	M12x70	2
	M12x100	6
	M12	8
	12,2	8
	13	2
	Ø36xØ13x3	6

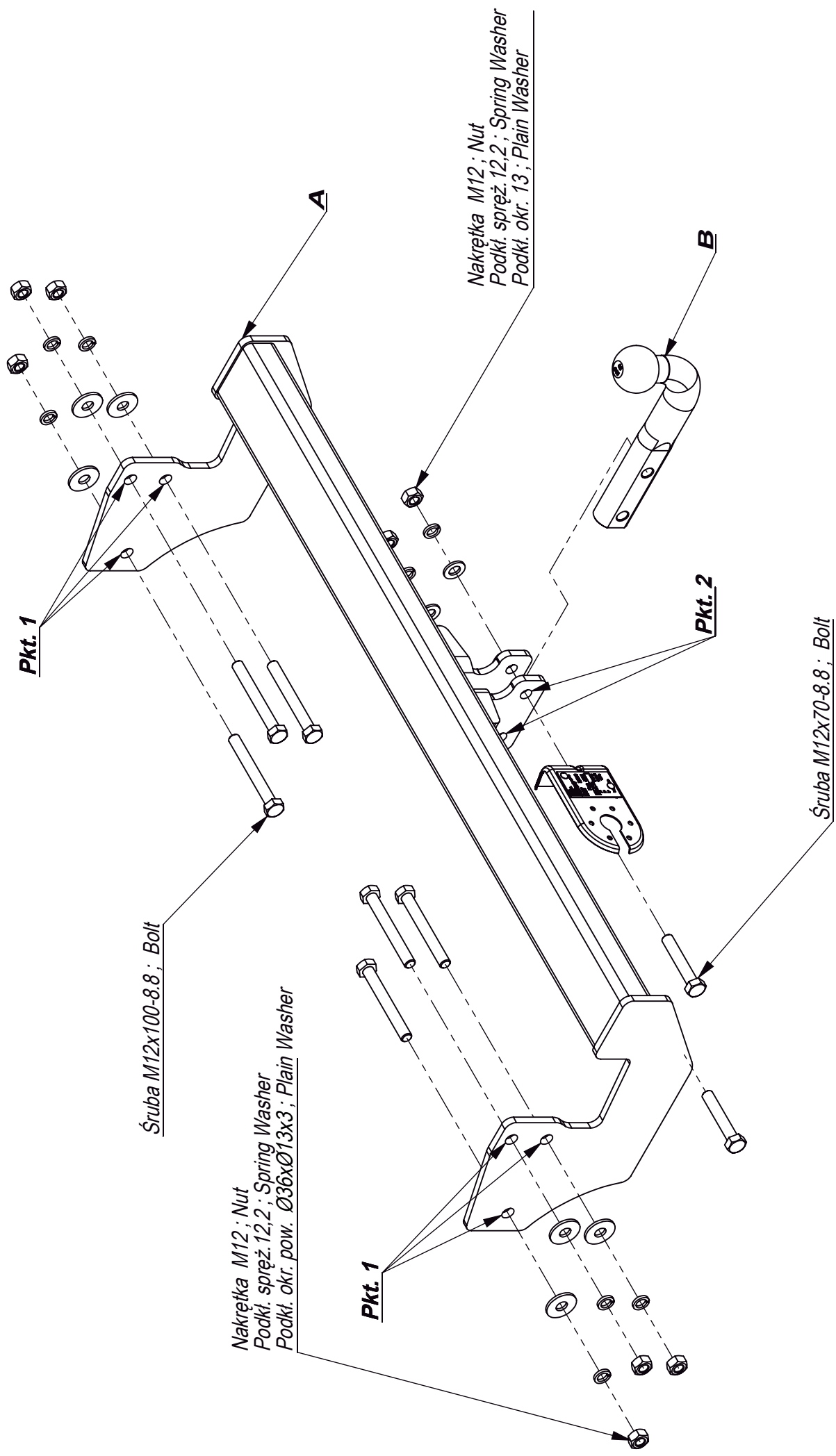

Śruba M12x100-8.8 ; Bolt

Nakrętka M12 ; Nut  
 Podkł. spręż. 12,2 ; Spring Washer  
 Podkł. okr. pow. Ø36xØ13x3 ; Plain Washer

Nakrętka M12 ; Nut  
 Podkł. spręż. 12,2 ; Spring Washer  
 Podkł. okr. 13 ; Plain Washer

Śruba M12x70-8.8 ; Bolt



Nr katalogowy

Marka

**M/020**

**Mercedes Vito Vian 09/03** ->

96-111 Kowiesy, Chojnata 23 A  
 tel. +48 46 831 73 31

- Odkręcić zderzak i ucho holownicze (nie będzie już wykorzystane).
- Poprzez otwory w ramie przykręcić lekko belkę zaczepu A śrubami M12x100 8.8 (pkt 1).
- Dokręcić wszystkie śruby z momentem wg tabeli.
- Wykonać wycięcie w dolnej części zderzaka wg rysunku.
- Przykręcić zderzak.
- Przykręcić kulę i blachę gniazda elektrycznego śrubami M12x70 8.8.
- Podłączyć instalację elektryczną.

- Unscrew the bumper and towing eye (it will not be used any more).
- Screw slightly the main bar A, through the holes in the chassis, with bolts M12x100 8.8 (point 1).
- Tighten all the bolts according to the torque setting- see the table.
- Cut out the fragment in the lower part of the bumper, according to the drawing.
- Screw the bumper.
- Fix the ball and electric plate with bolts M12x70 8.8.
- Connect the electric wires.

- Dévisser le pare-chocs et crochet (il ne sera plus utilisé),
- Visser légèrement la traverse d'attache A, a travers les ouvertures de renfort, par les boulons M12x100 8.8 (point 1),
- Serrer tous les boulons avec un couple de serrage selon tableau,
- Ouvrir le pare-chocs en partie basse selon croquis,
- Fixer un pare-chocs,
- Visser le crochet d'attelage et socle de prise électrique par les boulons M12x70 8.8.
- Raccorder le circuit électrique.

- Die Stoßstange und die Abschleppöse abschrauben (wird nicht mehr gebraucht).
- Durch die Öffnung im Gestell, den Querbalken A mit den Schrauben M12x100 (Punkt 1) locker anschrauben.
- Alle Schrauben mit dem in der Tabelle angegebenen Drehmoment festziehen.
- Einen Ausschnitt im unteren Teil der Stoßstange nach der Zeichnung ausführen.
- Die Stoßstange anschrauben.
- Die Kugel mit der Steckdosenhalterung mit den Schrauben M12x70 8.8 anschrauben.
- Die Elektroinstallation anschließen.

- Desenroscar el parachoques y la argolla de remolque.
- Poner la viga de la bola y atornillarla con tornillos M12x100 8.8 (p. 1).
- Apretar todos los tornillos con el par según la tabla anterior.
- Hacer un entalle en la parte inferior del parachoques según el dibujo.
- Instalar el parachoques.
- Apretar la bola y la placa eléctrica con tornillos M12x70 8.8.
- Conectar la instalación eléctrica.

