



# Mercedes

GLC (X253) + AMG-Pakiet

09/2015 -

Cat. No. M/A53

**E20** 55R02/00\*006042\*00

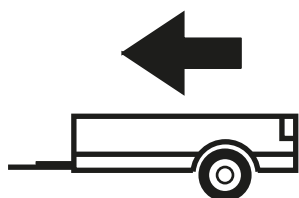

2 730kg

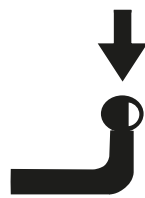

100kg

**D** = 13,32kN

$$D \text{ (kN)} = \frac{\text{MAX kg} \times \text{MAX kg}}{\text{MAX kg} + \text{MAX kg}} \times 0,00981$$

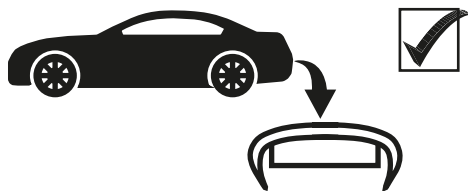

**IMIOLA HAK-POL**

96-111 KOWIESY, CHOJNATA 23A, POLAND

tel. +48 46 831 73 31, fax +48 831 74 29

e-mail: office@imiola.pl, www.imiola.pl

Rys. 25a

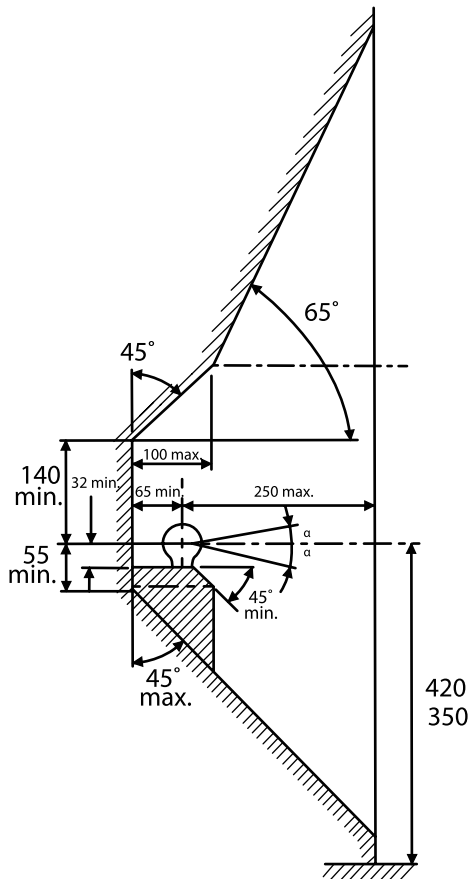

Rys. 25b

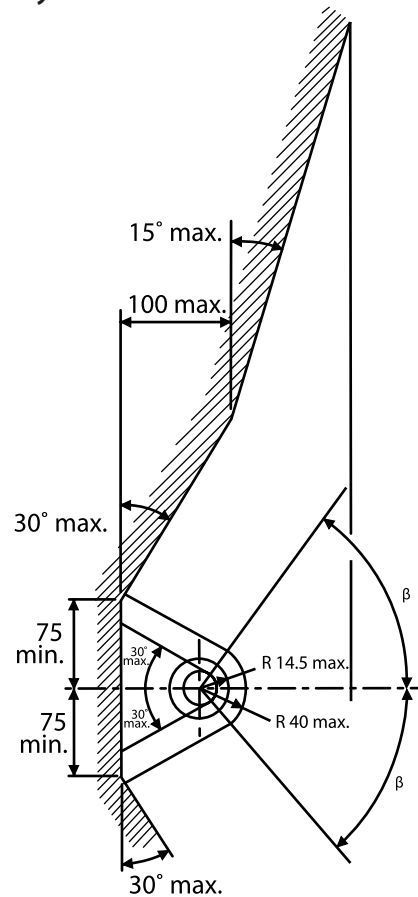

**PL** Należy zagwarantować przestrzeń swobodną według załącznika VII, rysunek 25a/b Regulaminu EKG ONZ 55.02 przy dopuszczalnym ciężarze całkowitym pojazdu.

**FR** L'espace libre doit être garanti conformément à l'annexe VII, illustration de la réglementation 55.02 CE pour un poids total en charge autorisé du véhicule.









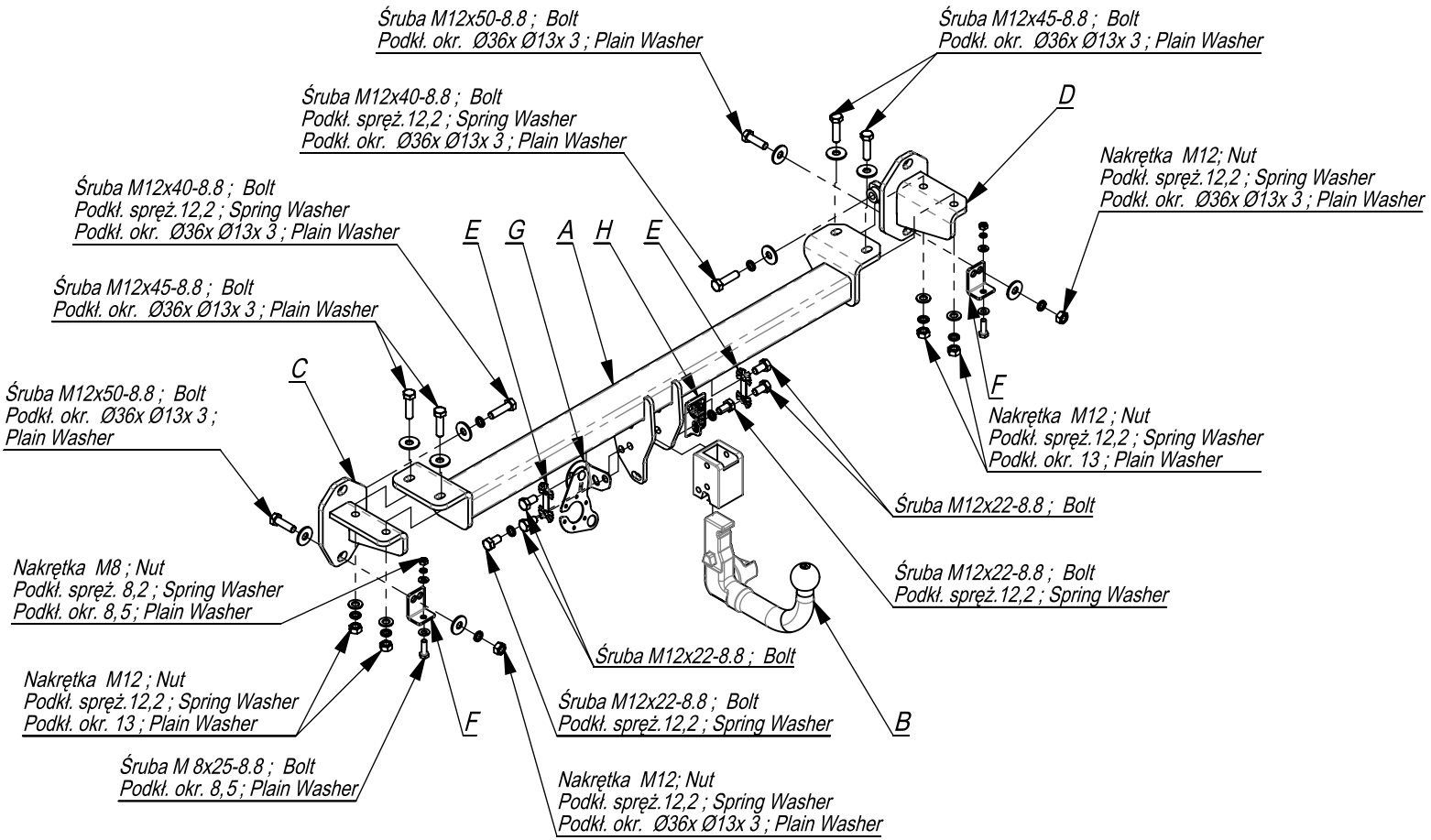

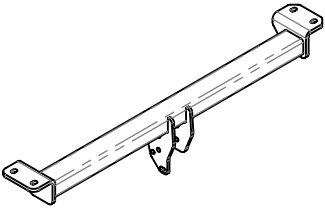

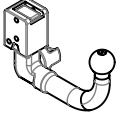
**GB** The clearance specified in appendix VII, diagram 25a/b of Regulation No. 55.02 UN EU must be guaranteed at laden weight of the vehicle.

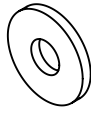
**DE** Der Freiraum nach Anhang VII, Abbildung 25a/b der Vorschriften 55.02 EG ist zu gewährleisten bei zulässigem Gesamtgewicht des Fahrzeuges.

Moment skręcający dla śrub i nakrętek (8.8) Torgue settings for nuts and bolts (8.8)	
M8	25Nm
M10	55Nm
M12	85Nm
M14	135Nm
M16	195Nm





	A	x1		M12x50	2
				M12x45	4
				M12x40	2
				M12x22	6
				M8x25	2
	B	x1		M12	6
				M8	2
	C	x1		Ø36x Ø13x 3	10
				13	4
	D	x1		8,5	4
				12,2	10
	E	x2		8,2	2
	F	x2			
	G	x1			
	H	x1			



