



CITROEN C8
FIAT ULYSSE II
LANCIA PHEDRA
PEUGEOT 807

2002 - 06/2011

Cat. No. **F/020**

e20

e20*94/20*0897*00

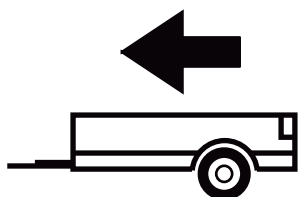

1900Kg

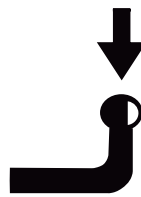

80Kg

D = 10,20kN

D (kN) =



MAX kg

x

MAX kg

x 0,00981



MAX kg

+

MAX kg

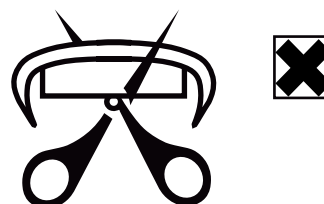
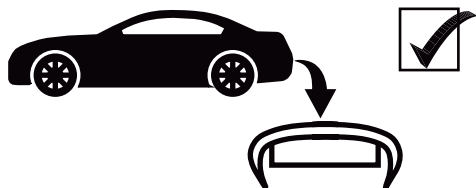

IMIOLA HAK-POL

96-111 KOWIESY, CHOJNATA 23A, POLAND

Tel. + 48 46 831 73 31, fax +48 831 74 29

e-mail: office@imiola.pl, www.imiola.pl

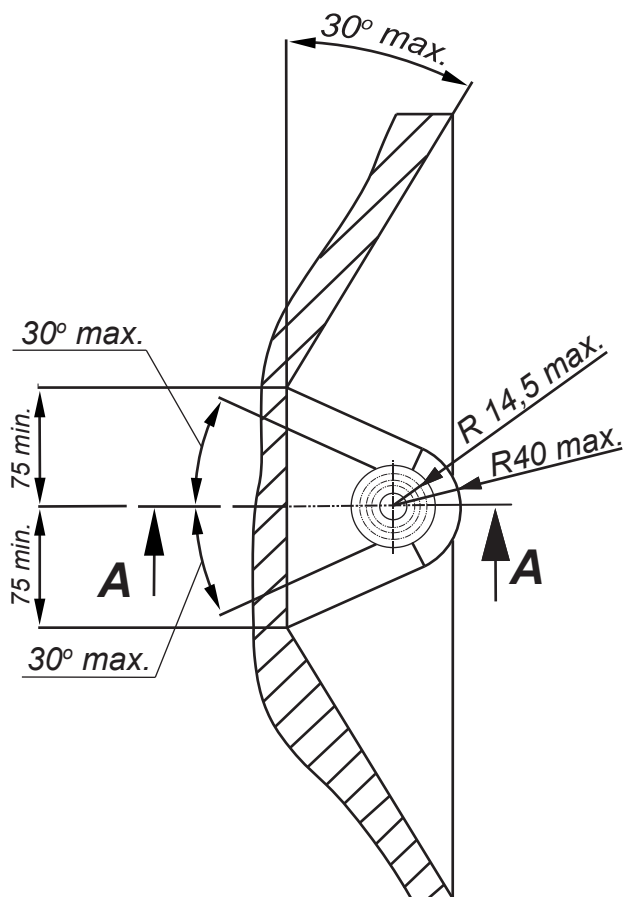

PRZEKRÓJ A-A

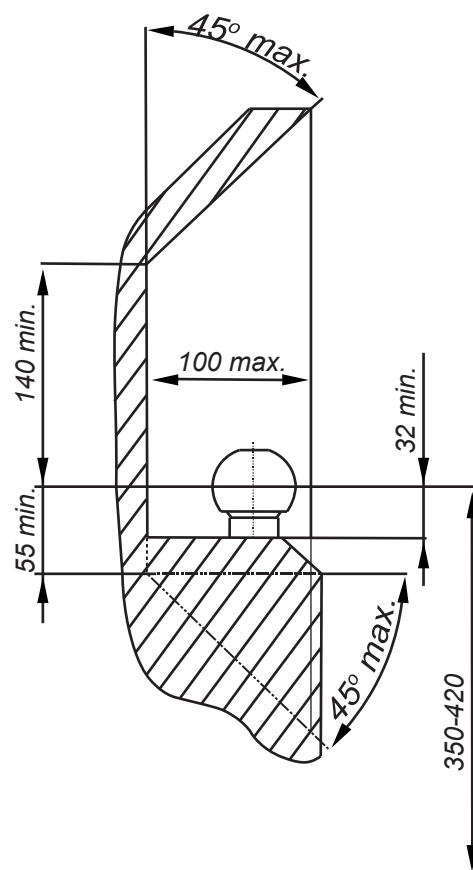

PL Należy zagwarantować przestrzeń swobodną według załącznika VII, rysunek 25a/b Regulaminu EKG ONZ 55.01 przy dopuszczalnym ciężarze całkowitym pojazdu.

F L'espace libre doit être garanti conformément à l'annexe VII, illustration de la réglementation 55.01 CE pour un poids total en charge autorisé du véhicule.







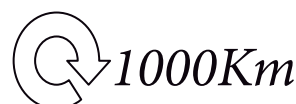

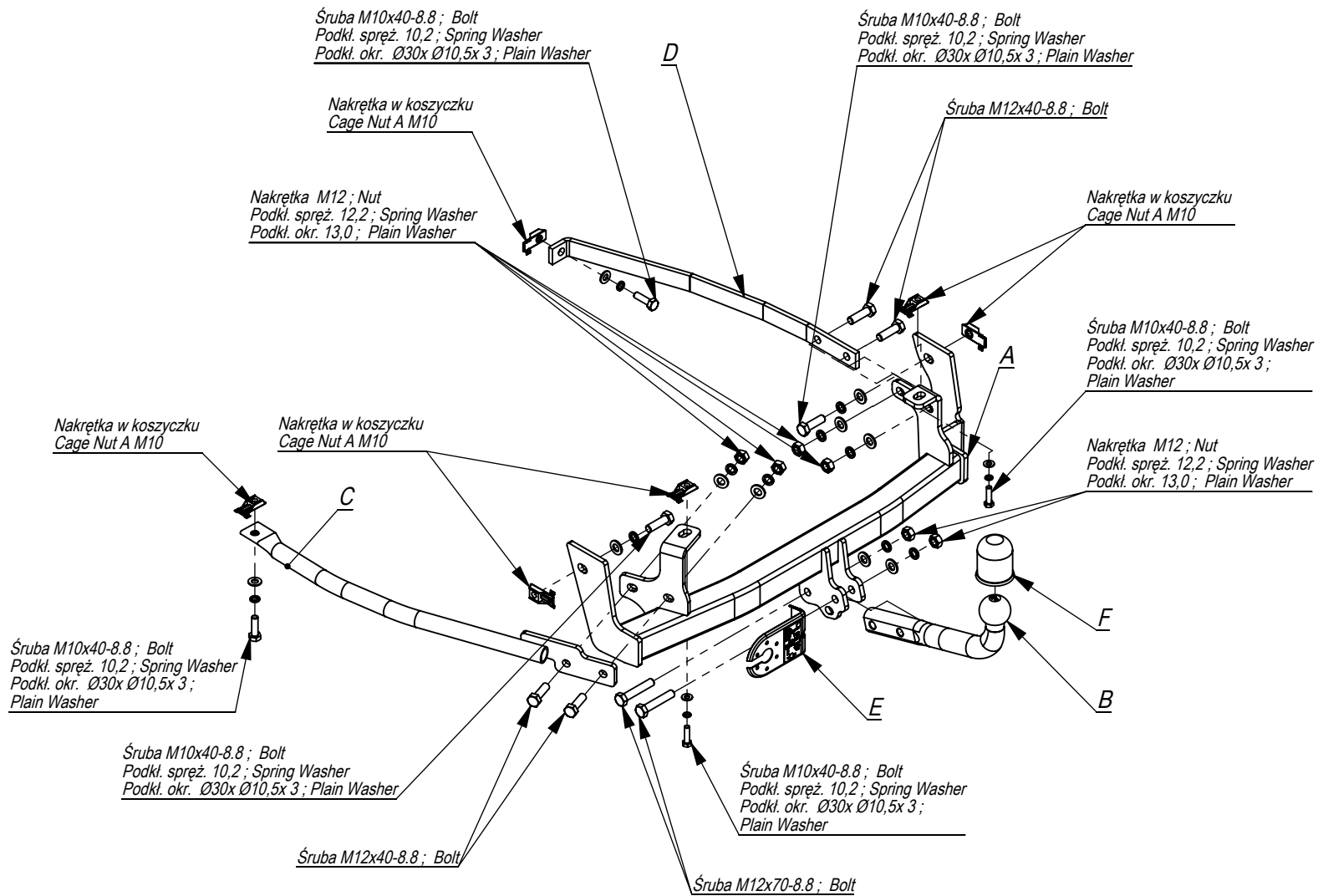
GB The clearance specified in appendix VII, diagram 25a/b of Regulation No. 55.01 UN EU must be guaranteed at laden weight of the vehicle.

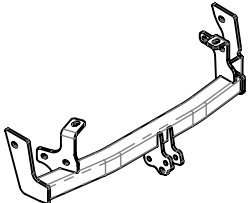
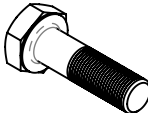
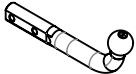
D Der Freiraum nach Anhang VII, Abbildung 25a/b der Vorschriften 55.01 EG ist zu gew 25a/b abzugeben bei zulässigem Gesamtgewicht des Fahrzeuges.

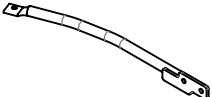
Moment skręcający dla śrub i nakrętek (8.8) Torgue settings for nuts and bolts (8.8)	
M8	25Nm
M10	55Nm
M12	85Nm
M14	135Nm
M16	195Nm



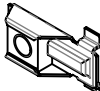

	A	x1		M12x70	2
				M12x40	4
				M10x40	6
	B	x1		M12	6
	C	x1		Ø30xØ10,5x3	6
	D	x1		13	6
	E	x1		12,2	6
				10,2	6
	F	x1		M10	6

- Zdemontować zderzak.
- Udrożnić technologiczne otwory zaklejone plastrem w kolorze podwozia.
- W otwory te należy włożyć nakrętki w koszyczku „Caget nuts” (pkt 3 i 4).
- Przyłożyć hak do podwozia w taki sposób, aby otwory haka pokrywały się z technologicznymi otworami w samochodzie, a następnie skręcić śrubami M10x40 8.8 (pkt 2,5).
- Przykręcić elementy C i D (pkt 1, 3 i 4).
- Zamontować zderzak.
- Dokręcić śruby z momentem wg tabeli.
- Dokręcić kulę i podstawę gniazda elektrycznego.
- Podłączyć instalację elektryczną.

- Disassemble the bumper.
- The technological holes stuck with slice in colour of the chassis make permeable.
- Insert the “Caget nuts” in these holes (point 3 and 4).
- Put the tow bar to the chassis in this way, so the holes of the tow bar cover the technological holes in the car, and next screw with bolts M10x40 8.8 (point 2,5).
- Screw the elements C and D (point 1, 3 and 4).
- Assemble the bumper.
- Tighten all the bolts according to the torque setting- see the table.
- Fix the ball and electric plate.
- Connect the electric wires.

- Déposer le pare-chocs,
- Déboucher les ouvertures collées par emplâtre, couleur identique que châssis,
- Placer les blocs d'écrou "Caget nuts" dans ces ouvertures (point 3 et 4),
- Présenter le crochet au châssis de sorte à ce que ces ouvertures soient dans la même axe que celles de ouverture de voiture, ensuite visser par les boulons M10x40 8.8 (point 2,5),
- Visser les éléments C et D (point 1, 3 et 4),
- Poser le pare-chocs,
- Serrer les boulons avec un couple de serrage selon tableau,
- Serrer le crochet d'attelage et socle de prise électrique,
- Raccorder le circuit électrique.

- Die Stoßstange entfernen.
- Die vom Werk aus vorhandenen Öffnungen, verklebt mit einem Paster in der Gestellfarbe, durchlässig machen.
- In diese Öffnungen die Muttern in den Korb „Caget nuts“ (Punkt 3,4) einlegen.
- Die Anhängerkupplung an das Gestell so anlegen, dass die Öffnungen der Anhängerkupplung sich mit den vom Werk aus vorhandenen im Wagen Öffnungen decken, dann mit den Schrauben M10x40 8.8 (Punkt 2,5) verschrauben.
- Die Tragteile C und D (Punkt 1,3,4) einschrauben.
- Die Stoßstange einbauen.
- Alle Schrauben mit dem in der Tabelle angegebenen Drehmoment festziehen.
- Die Kugel und die Steckdosenhalterung anschrauben.
- Die Elektroinstallation anschließen.

- Desenrosque el parachoques.
- Retire la cinta que cubre los agujeros de fábrica en los largueros.
- Inserte la Cuget Nut M10 en los largueros a través de las aberturas de fábrica.
- Fijar los elementos C y D a los largueros con tornillos M10x40 8.8 (punto 3,4).
- Apretar una barra el gancho de remolque A con los tornillos M10x40 8.8 (punto 2,5).
- Montar el parachoques.
- Apretar todos los tornillos con el par según la tabla anterior.
- Apretar la bola y la placa de la toma eléctrica.
- Conectar la instalación eléctrica.

