



Cat. No. **J/070**

JEEP COMPASS (MK) (excl. Rallye)

08/06- 03/11

JEEP PATRIOT (MK)

02/07-03/11

E20

E20 55R-01 5076

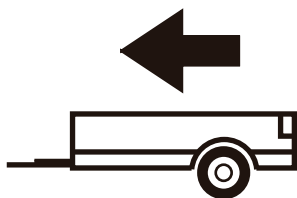

2000kg

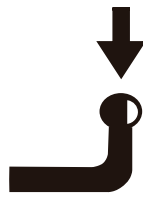

105kg

D=10,11kN

D (kN) =



MAX kg

x

MAX kg

x 0,00981



MAX kg

+

MAX kg



IMIOLA HAK-POL

96-111 KOWIESY, CHOJNATA 23A, POLAND

Tel. + 48 46 831 73 31, fax +48 831 74 29

e-mail: office@imiola.pl, www.imiola.pl

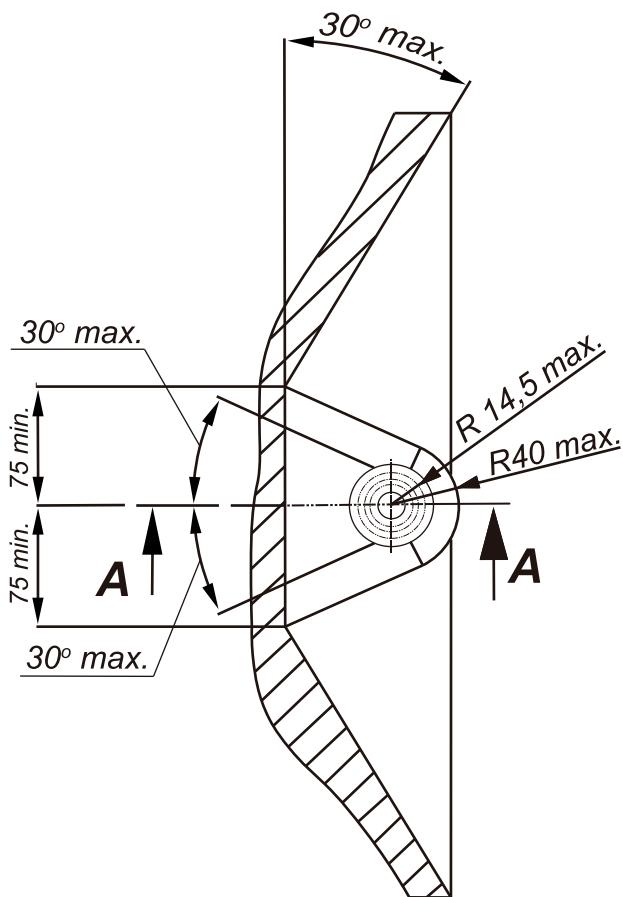

PRZEKRÓJ A-A

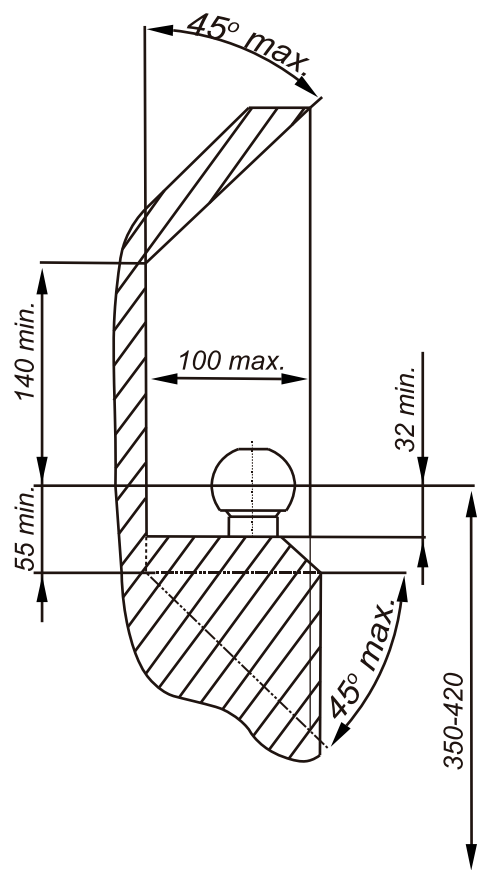

PL Należy zagwarantować przestrzeń swobodną według załącznika VII, rysunek 25a/b Regulaminu EKG ONZ 55.01 przy dopuszczalnym ciężarze całkowitym pojazdu.

F L'espace libre doit être garanti conformément à l'annexe VII, illustration de la réglementation 55.01 CE pour un poids total en charge autorisé du véhicule.





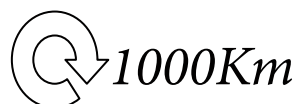

GB The clearance specified in appendix VII, diagram 25a/b of Regulation No. 55.01 UN EU must be guaranteed at laden weight of the vehicle.

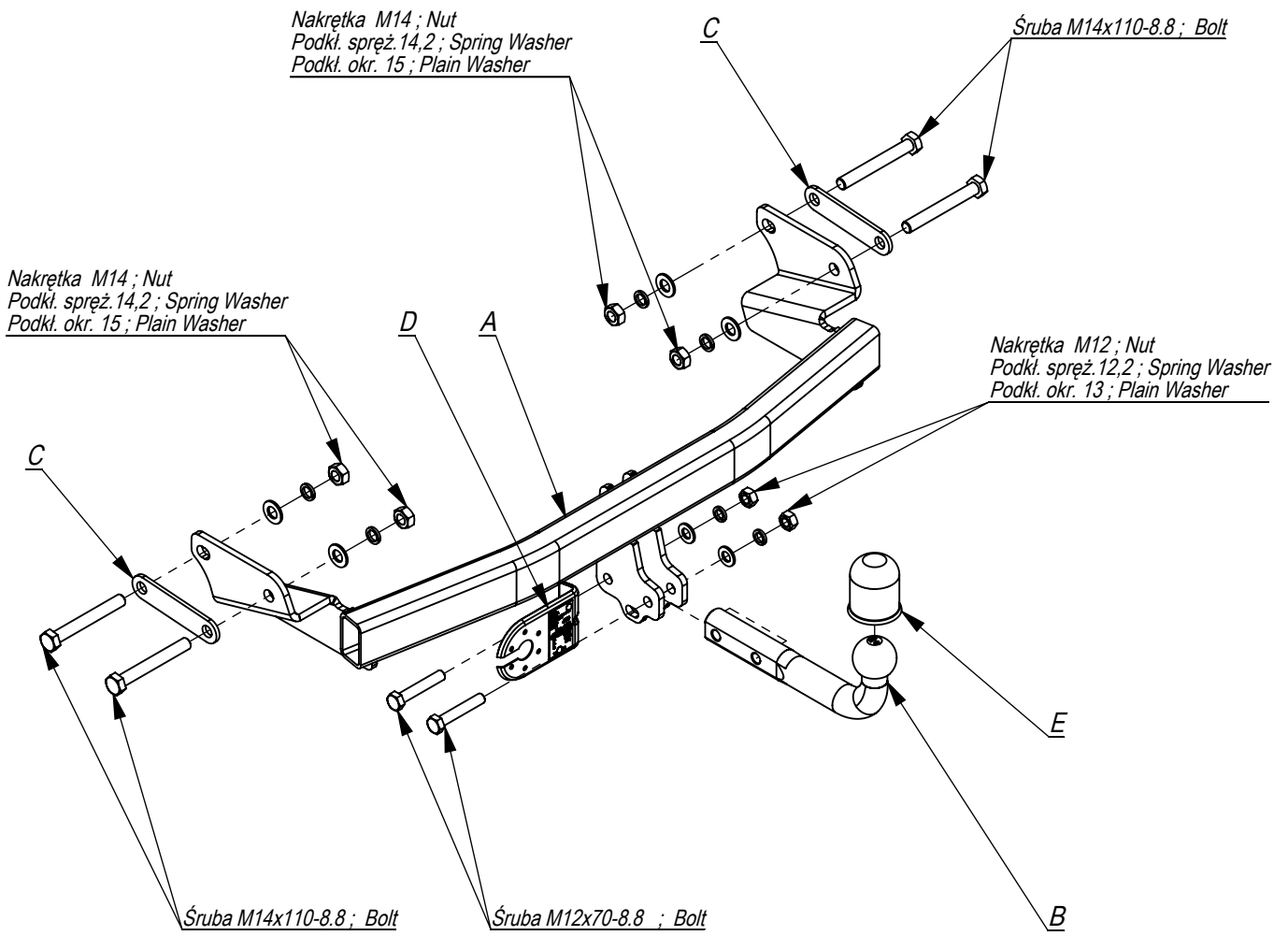
D Der Freiraum nach Anhang VII, Abbildung 25a/b der Vorschriften 55.01 EG ist zu gewährleisten bei zulässigem Gesamtgewicht des Fahrzeuges.

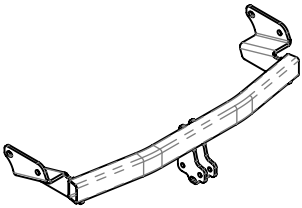
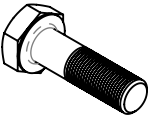
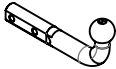
Moment skręcający dla śrub i nakrętek (8.8) Torque settings for nuts and bolts (8.8)	
M8	25Nm
M10	55Nm
M12	85Nm
M14	135Nm
M16	195Nm





	A	x1		M14x110	4
				M12x70	2
	B	x1		M14	4
				M12	2
	C	x2		15	4
				13	2
	D	x1		14,2	4
				12,2	2
	E	x1			

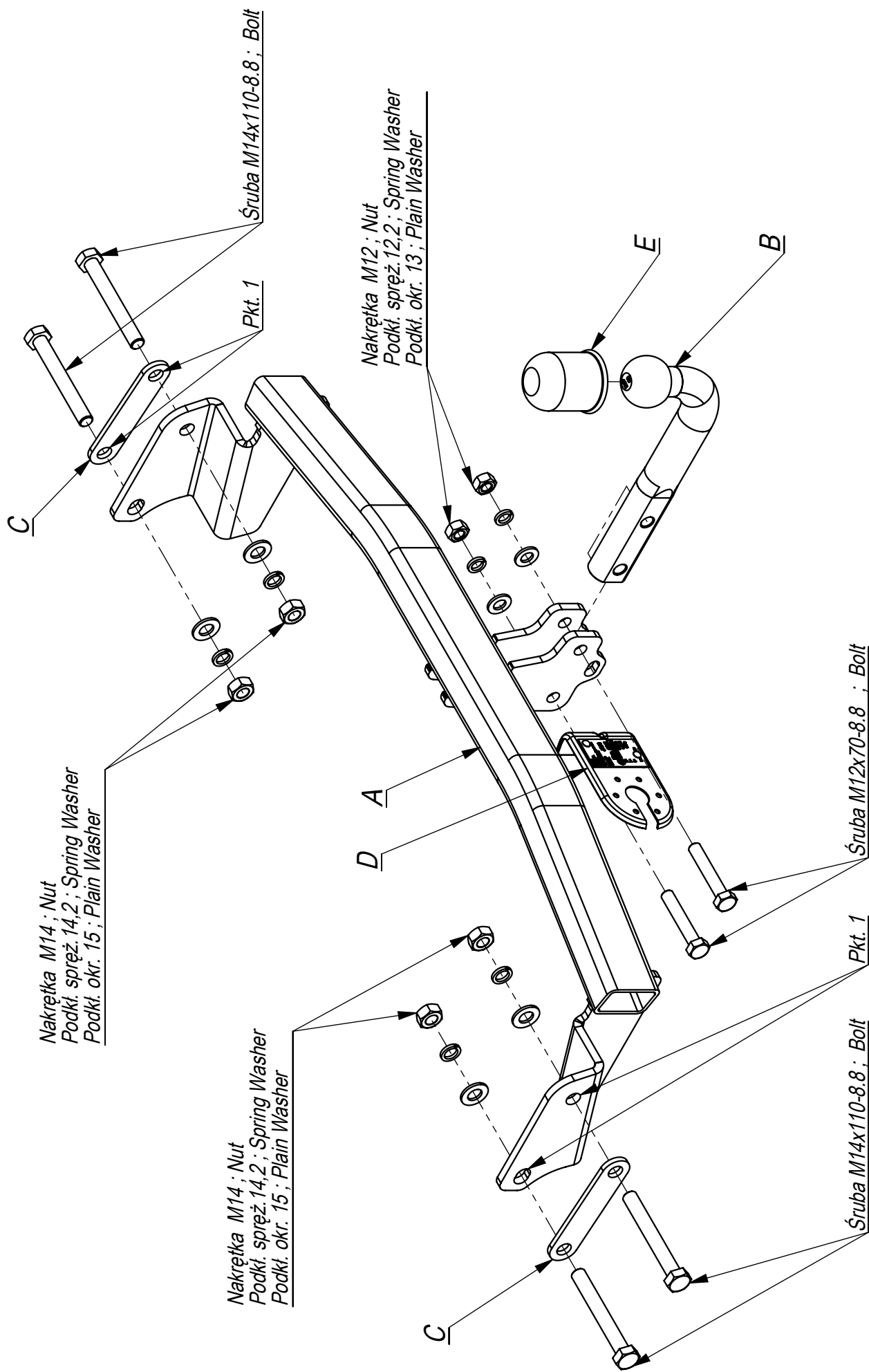

- Udrożnić technologiczne otwory w podłużnicach.
- Wyciąć w zderzaku w części środkowej 50mm x110mm na uchwyt kuli.
- Przykręcić do podłużnic belkę haka A śrubami M14x110x8.8(pkt 1) stosując elementy C.
- Dokręcić wszystkie śruby z momentem wg tabeli.
- Przykręcić kulę i blachę gniazda elektrycznego.
- Podłączyć instalację elektryczną.

- Clean out the technological holes in the frame side members.
- Cut out the fragment of bumper 50 mm x110 mm, in its central part to put the towball handles.
- Screw the bar A to the frame side members with bolts M14x110 8.8 (point 1) using the elements C.
- Tighten all the bolts according to the torque setting- see the table.
- Fix the ball and electric plate.
- Connect the electric wires.

- Déboucher les trous technologiques dans les longerons.
- Faire une entaille 50 mm x 110 mm dans la partie centrale du pare-chocs, pour l'encastrement de la boule.
- Visser la barre de crochet A aux longerons, avec les boulons M14x110x8.8 (pt 1), en utilisant les éléments C.
- Serrer tous les boulons avec un couple de serrage selon tableau.
- Visser la boule et la tôle de la prise électrique.
- Brancher l'installation électrique.

- Die Löcher an den Seiten der Metallklammern machen durchlässig
- Setzen Sie die Seitenelemente der Hauptleiste in die Metallklammern ein und schrauben Sie sie mit den Schrauben M14X110 8.8 fest (Punkt 1).
- Schneiden Sie das 50x110-Fragment im unteren Teil des Stoßfängers aus.
- Ziehen Sie alle Schrauben entsprechend der Drehmomenteinstellung fest - siehe Tabelle.
- Schrauben Sie den Stoßfänger fest.
- Befestigen Sie den Ball und die elektrische Platte.
- Schließen Sie die elektrischen Kabel an.

- Los agujeros en los lados de las abrazaderas metálicas lo hacen permeable.
- Inserte los elementos laterales de la barra principal en las abrazaderas de metal,
- atornille con pernos M14X110 8.8(punto 1).
- Recorta el fragmento que mide 50x110 en la parte inferior del parachoques.
- Apriete todos los pernos de acuerdo con la conguración de torque: vea la tabla.
- Atornillar el parachoques.
- Repare la bola y la placa eléctrica.
- Conecte los cables eléctricos.

