



VOLVO XC70

10/2007 -

Cat. No. V/020

E20

E20 55R-01 4079

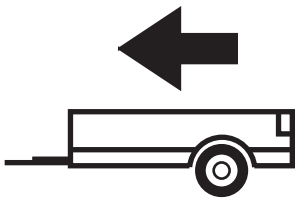

2100kg



90kg

D = 10,99kN

D (kN) =



MAX kg

x

MAX kg

x 0,00981



MAX kg

+

MAX kg



IMIOLA HAK-POL

96-111 KOWIESY, CHOJNATA 23A, POLAND

Tel. + 48 46 831 73 31, fax +48 831 74 29

e-mail: office@imiola.pl, www.imiola.pl

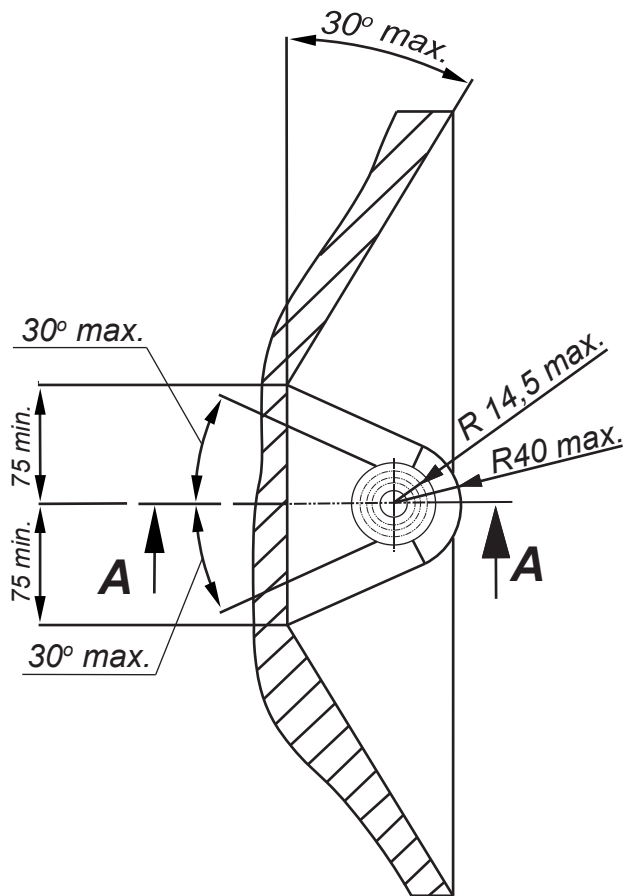

PRZEKRÓJ A-A

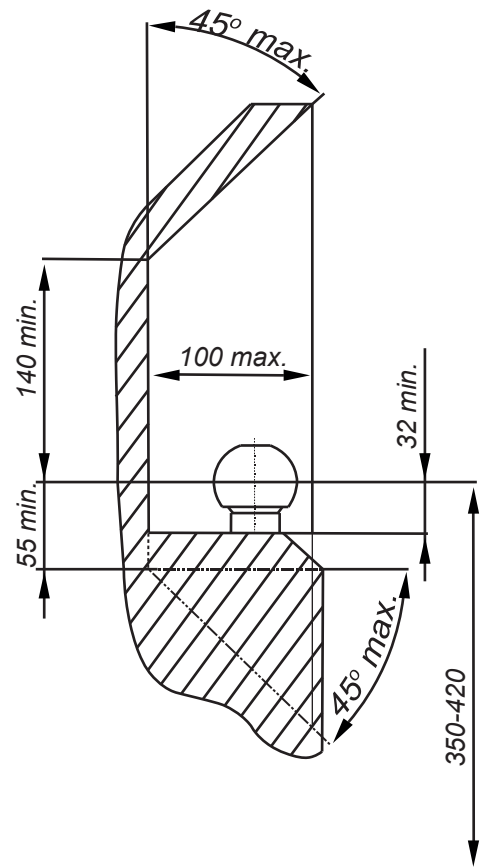

PL Należy zagwarantować przestrzeń swobodną według załącznika VII, rysunek 25a/b Regulaminu EKG ONZ 55.01 przy dopuszczalnym ciężarze całkowitym pojazdu.

F L'espace libre doit être garanti conformément à l'annexe VII, illustration de la réglementation 55.01 CE pour un poids total en charge autorisé du véhicule.

GB The clearance specified in appendix VII, diagram 25a/b of Regulation No. 55.01 UN EU must be guaranteed at laden weight of the vehicle.

D Der Freiraum nach Anhang VII, Abbildung 25a/b der Vorschriften 55.01 EG ist zu gew 25a/b abzugeben bei zulässigem Gesamtgewicht des Fahrzeuges.

Moment skręcący dla śrub i nakrętek (8.8) Torque settings for nuts and bolts (8.8)	
M8	25Nm
M10	55Nm
M12	85Nm
M14	135Nm
M16	195Nm

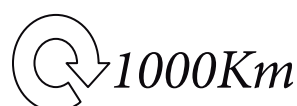

Śruba M12x45-8.8 ; Bolt
 Podkł. spręż. 12,2 ; Spring Washer
 Podkł. okr. Ø36xØ13x 3 ; Plain Washer

Śruba M12x50-8.8 ; Bolt

Nakrętka M12 ; Nut
 Podkł. spręż. 12,2 ; Spring Washer
 Podkł. okr. 13 ; Plain Washer





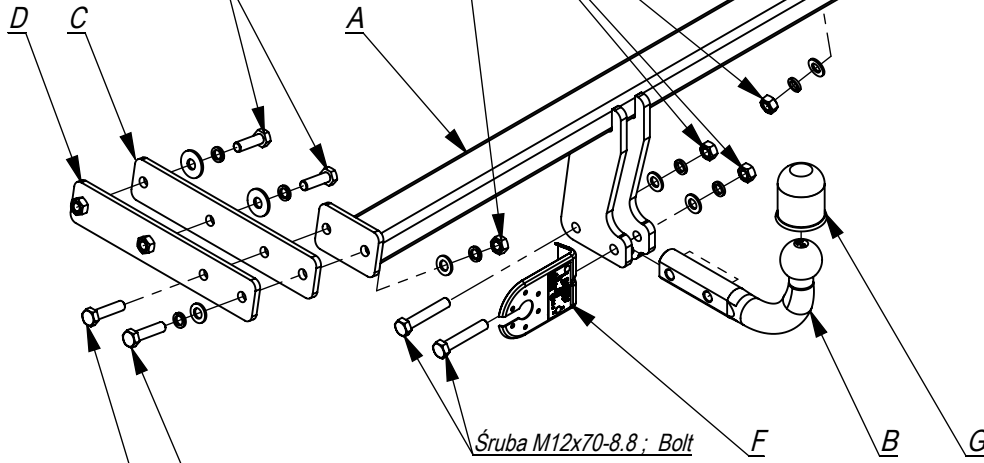

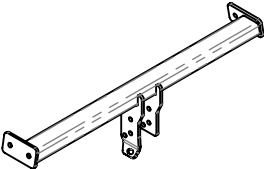
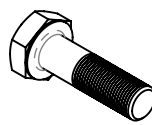
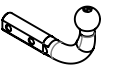

Śruba M12x45-8.8 ; Bolt
 Podkł. spręż. 12,2 ; Spring Washer
 Podkł. okr. Ø36xØ13x 3 ; Plain Washer

Śruba M12x50-8.8 ; Bolt
 Podkł. spręż. 12,2 ; Spring Washer
 Podkł. okr. 13 ; Plain Washer

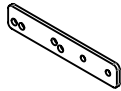
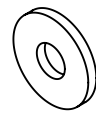
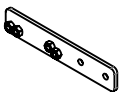

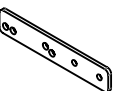
Śruba M12x50-8.8 ; Bolt
 Podkł. spręż. 12,2 ; Spring Washer
 Podkł. okr. 13 ; Plain Washer

Śruba M12x50-8.8 ; Bolt

	A	x1		M12x70	2
				M12x50	4
				M12x45	4
	B	x1		M12	4
	C	x2		Ø36xØ13x3	4
	D	x1		13	6
	E	x1		12,2	10
	F	x1			
	G	x1			

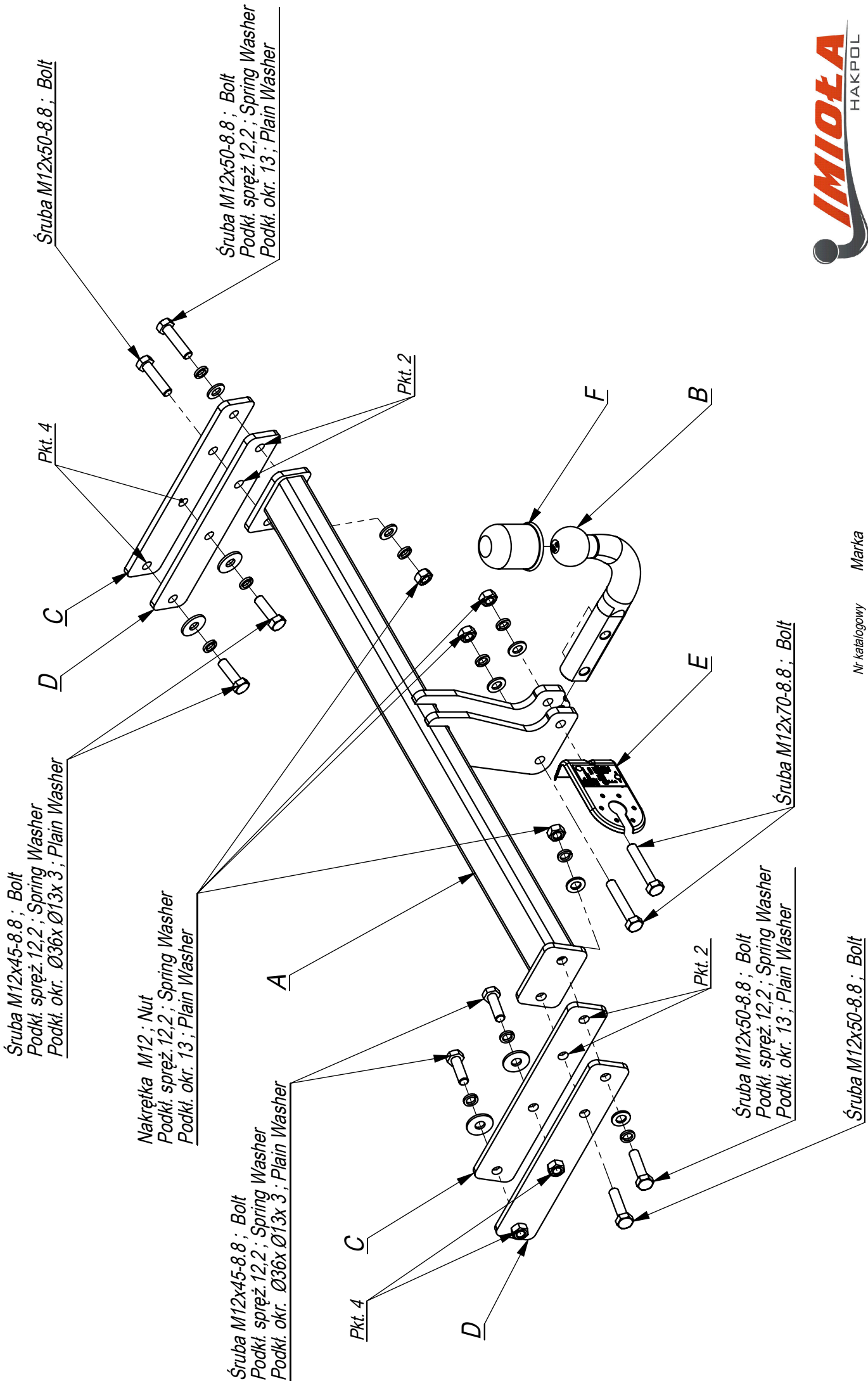

- Zdjąć zderzak.
- Odkręcić wzmocnienie zderzaka (nie będzie już montowane).
- Opuścić tłumik z zawiesia.
- Wsunąć elementy haka C i D w podłużnice i poprzez technologiczne otwory skręcić śrubami M12x45 8.8,
- Belkę haka A przykręcić do elementów C i D śrubami M12x50 8.8 (pkt 2).
- Przykręcić kulę i blachę gniazda elektrycznego.
- Dokręcić wszystkie śruby z momentem wg tabeli.
- Podłączyć instalację elektryczną.
- W części dolnej zderzaka wykonać wycięcie na szerokość uchwytu kuli.
- Przykręcić zderzak.
- Zamontować tłumik

- Disassemble the bumper.
- Unscrew the reinforcement of the bumper (it will not be used any more).
- Lower the damper from the hanger.
- Insert the elements C and D in the metal clamps and screw through the technological holes with bolts M12x45 8.8
- Screw the main bar A to the elements C and D with bolts M12x50 8.8 (point 2).
- Fix the ball and electric plate.
- Tighten all the bolts according to the torque setting- see the table.
- Connect the electric wires.

- Dévisser le pare-chocs.
- Dévisser la poutre pare-chocs de la voiture (elle ne sera plus utilisée).
- Enlever le pot d'échappement de la suspension.
- Glisser les éléments C et D dans les longerons et les visser légèrement avec les boulons M12x45 (point 1).
- Ensuite serrer les éléments C et D avec la barre de crochet A avec les boulons M12x50 8.8 (point2).
- Serrer tous les boulons avec un couple de serrage selon tableau.
- Visser le pot d'échappement.
- Installer le pare-chocs.
- Serrer la boule et la tôle de la prise électrique avec les boulons M12x70.
- Brancher l'installation électrique.

- Den Stoßfänger abschrauben.
- Den Stoßträger abschrauben (wird nicht mehr benötigt)..
- Den Schalldämpfer vom Halter absenken.
- Die Bauteile C und D in die Längsträger einschieben und mit Schrauben M12x45 leicht anziehen.
- Danach die Bauteile C und D mit den AHK-Querträger A mit Schrauben M12x50 8.8 (Punkt 2) zusammenschrauben.
- Ziehen Sie alle Schrauben mit dem Drehmoment gemäß der Tabelle an.
- Den Schalldämpfer anschrauben.
- Den Stoßfänger einsetzen.
- Schrauben Sie die Kugel und den Steckdosenblech mit den Schrauben M12x70 an.
- Die elektrische Installation anschließen.

- Desenrosque el parachoques.
- Desenrosque la barra de impacto (ya no es necesario).
- Baje el silenciador de la suspensión.
- Insertar los elementos C y D en los largueros atornillando ligeramente los tornillos M12x45 (punto 1).
- A continuación, fijar los elementos C y D a la barra del gancho A con los tornillos M12x50 8.8 (punto 2).
- Apretar todos los tornillos con el par según la tabla anterior.
- Fijar el silenciador.
- Montar el parachoques.
- Apretar la bola y la placa de la toma eléctrica usando tornillos M12x70.
- Conectar la instalación eléctrica.

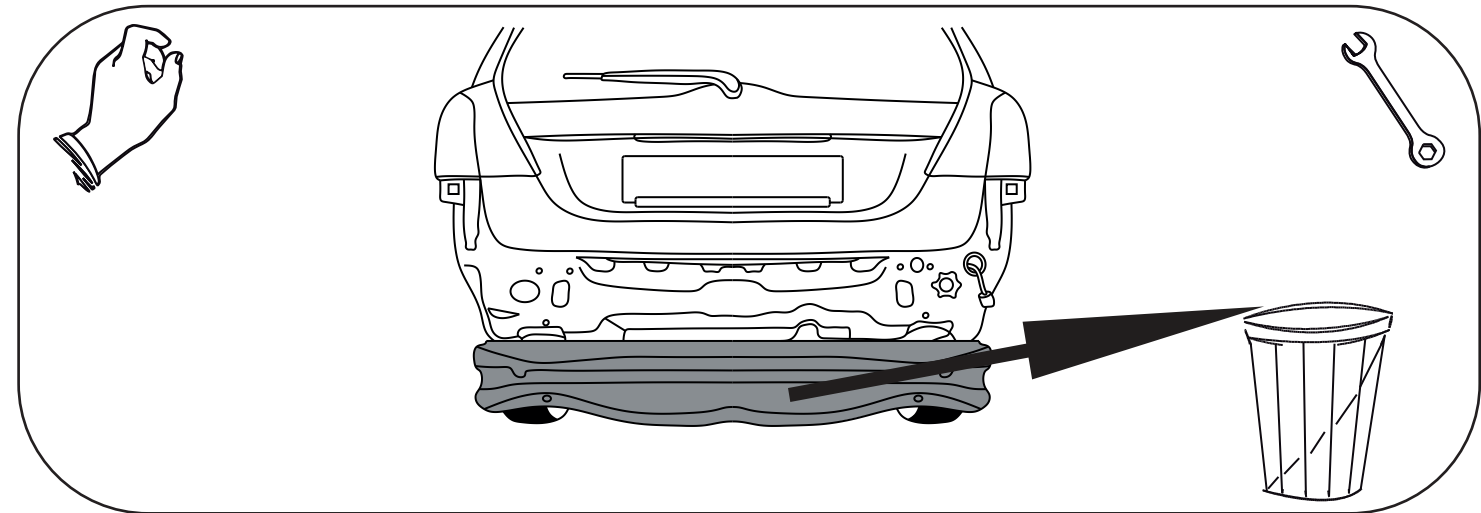
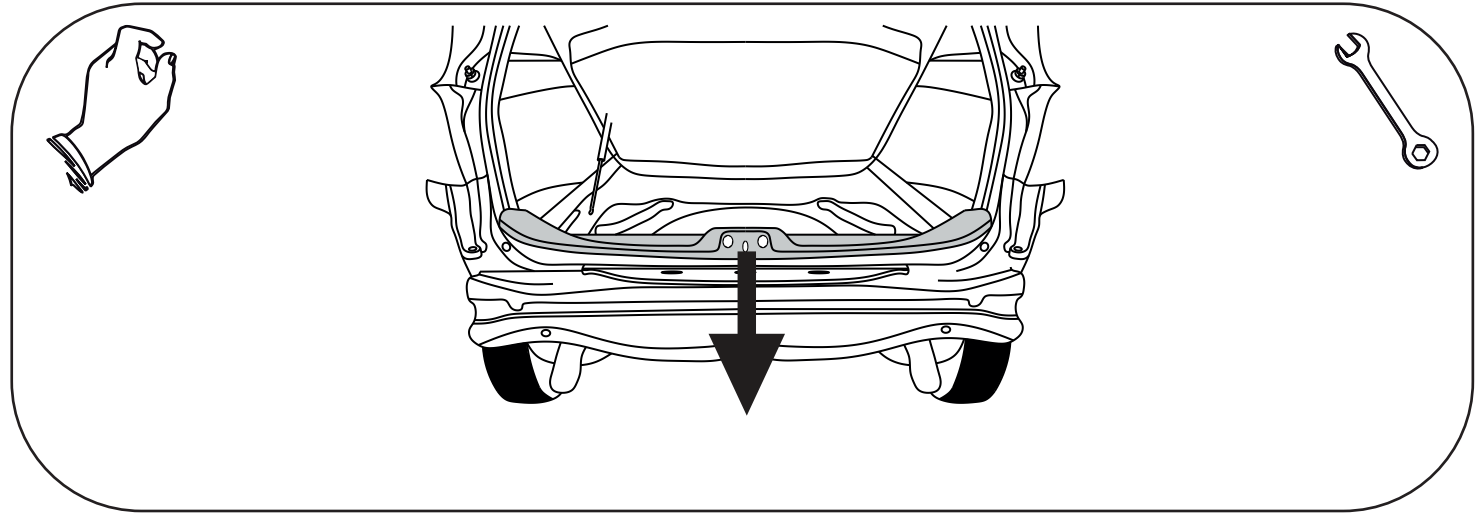
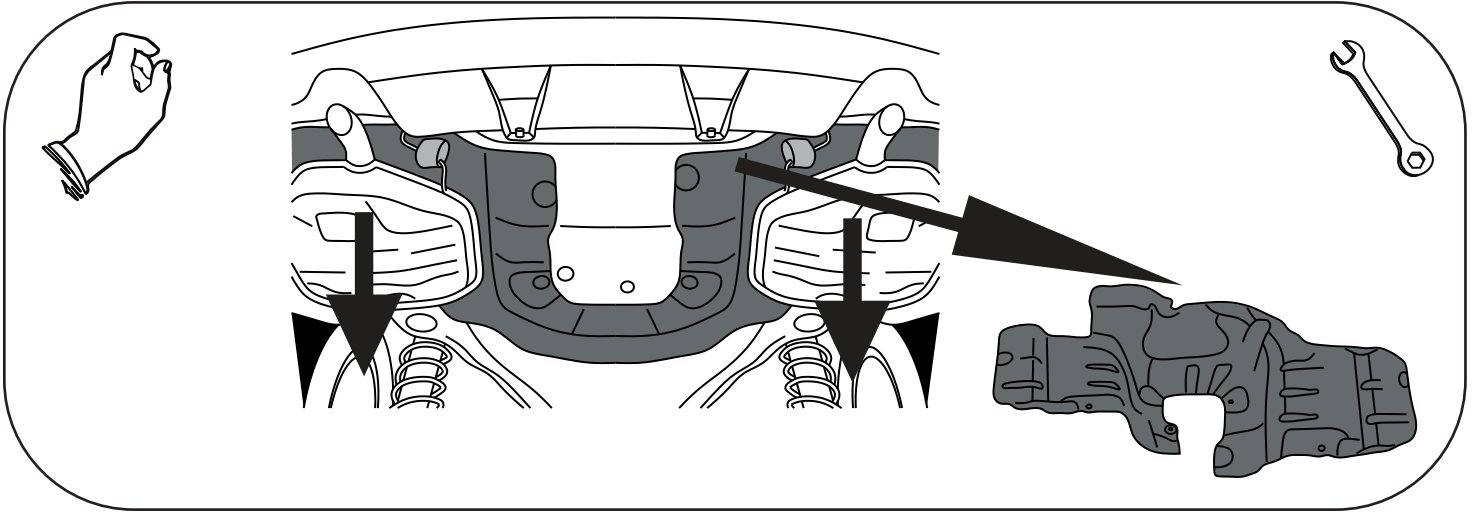
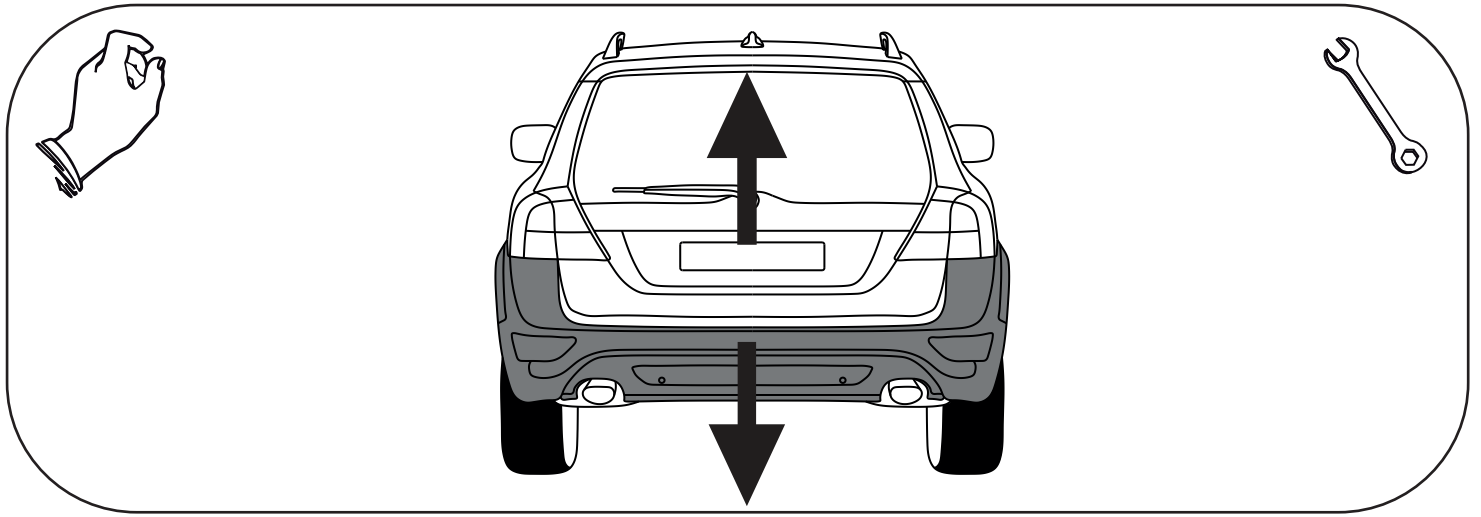

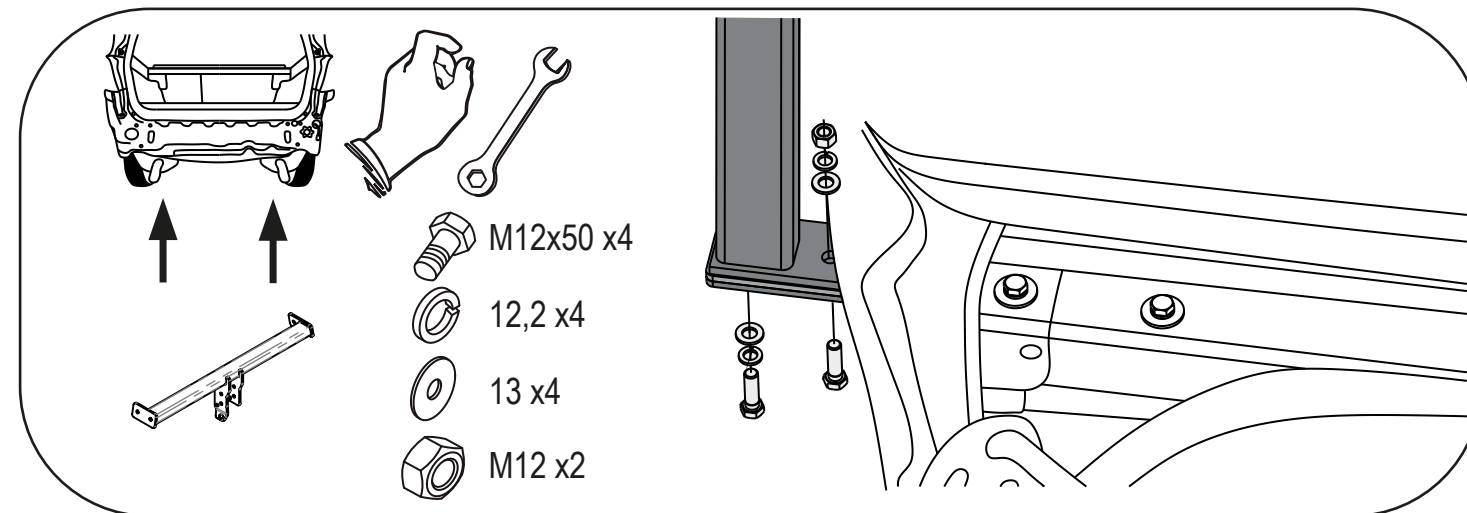
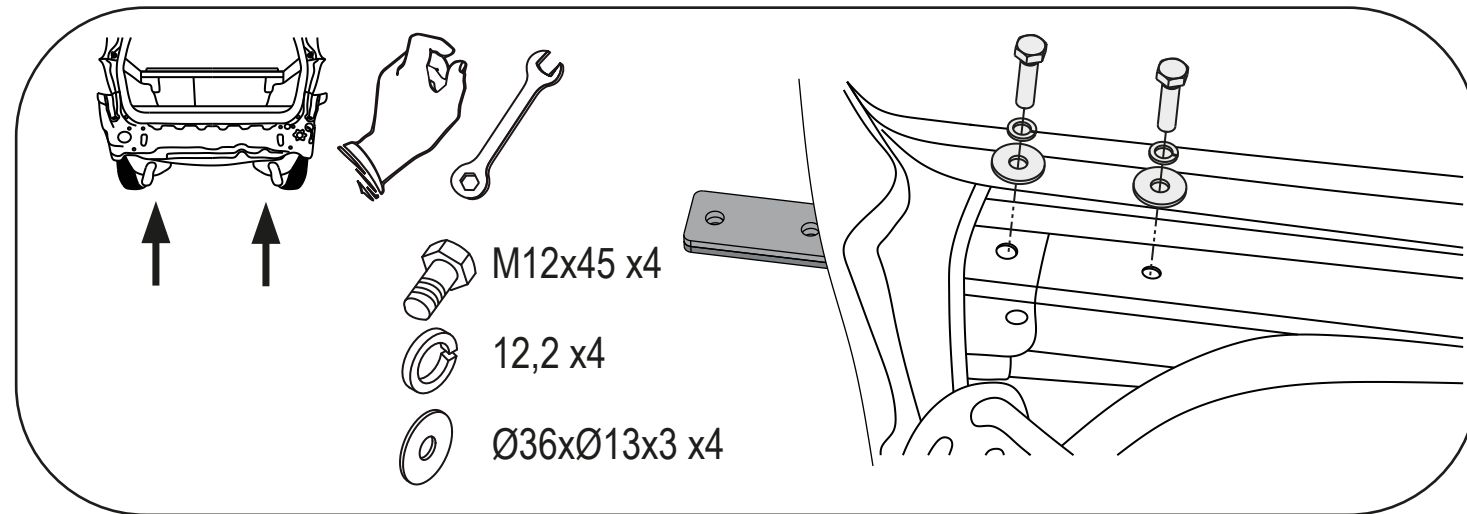
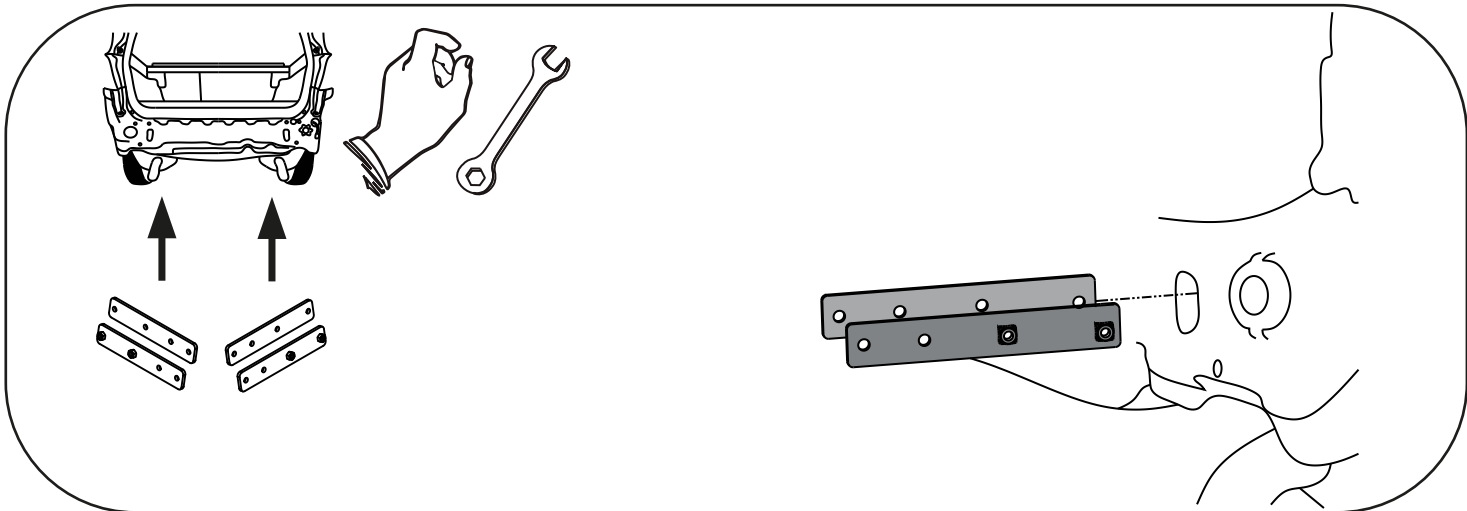
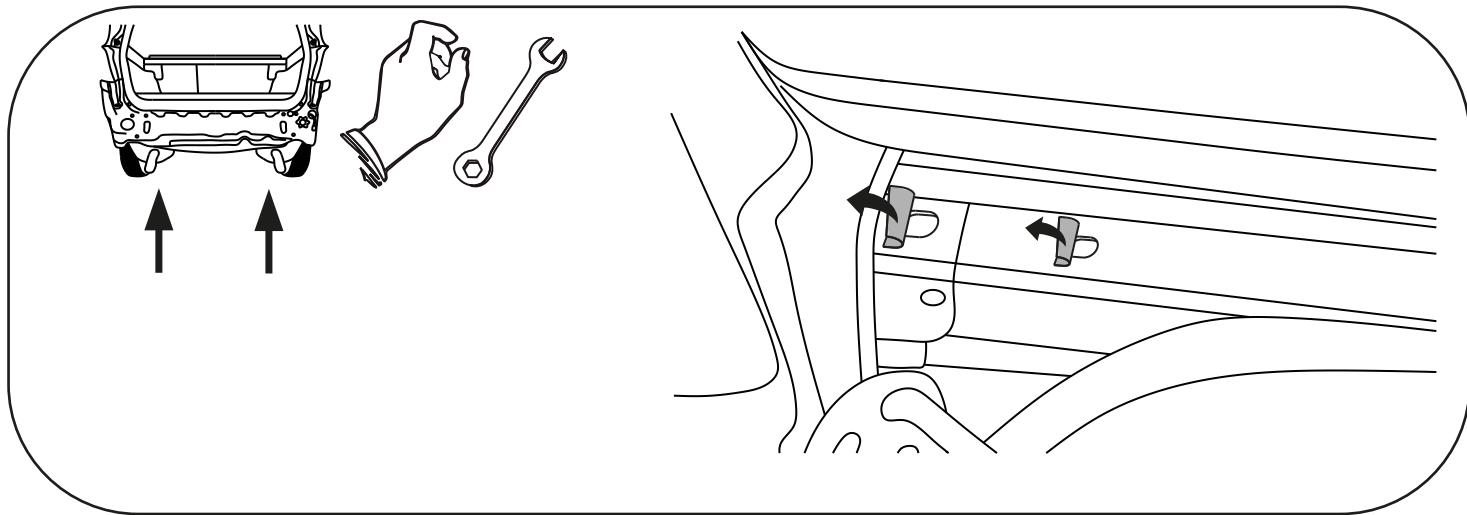

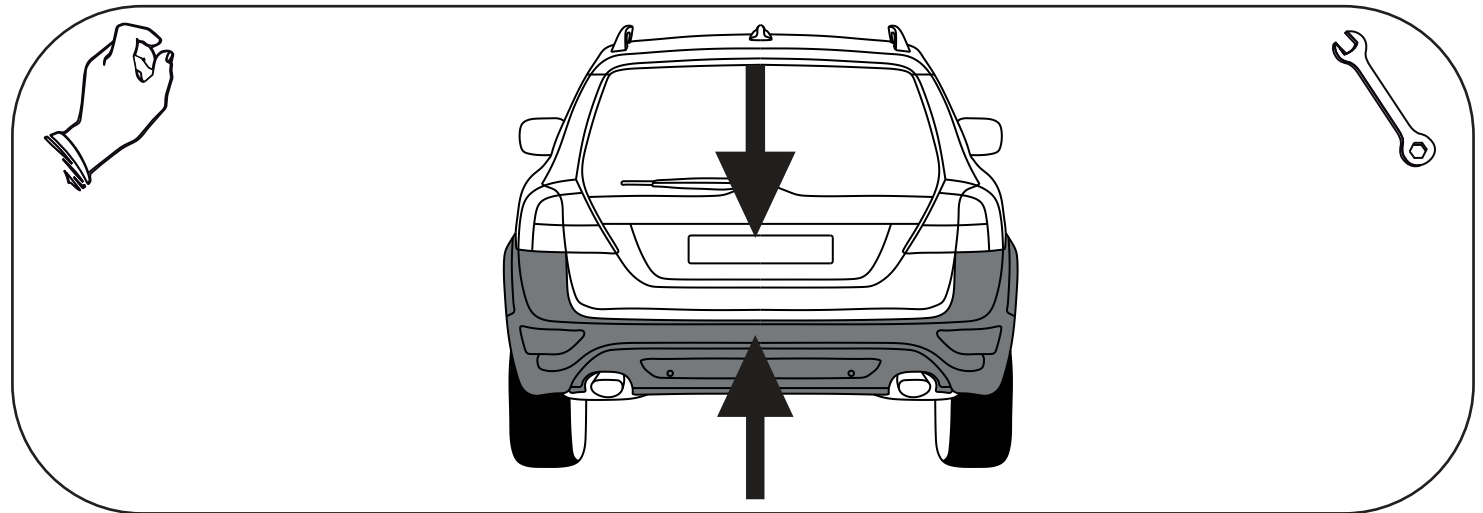
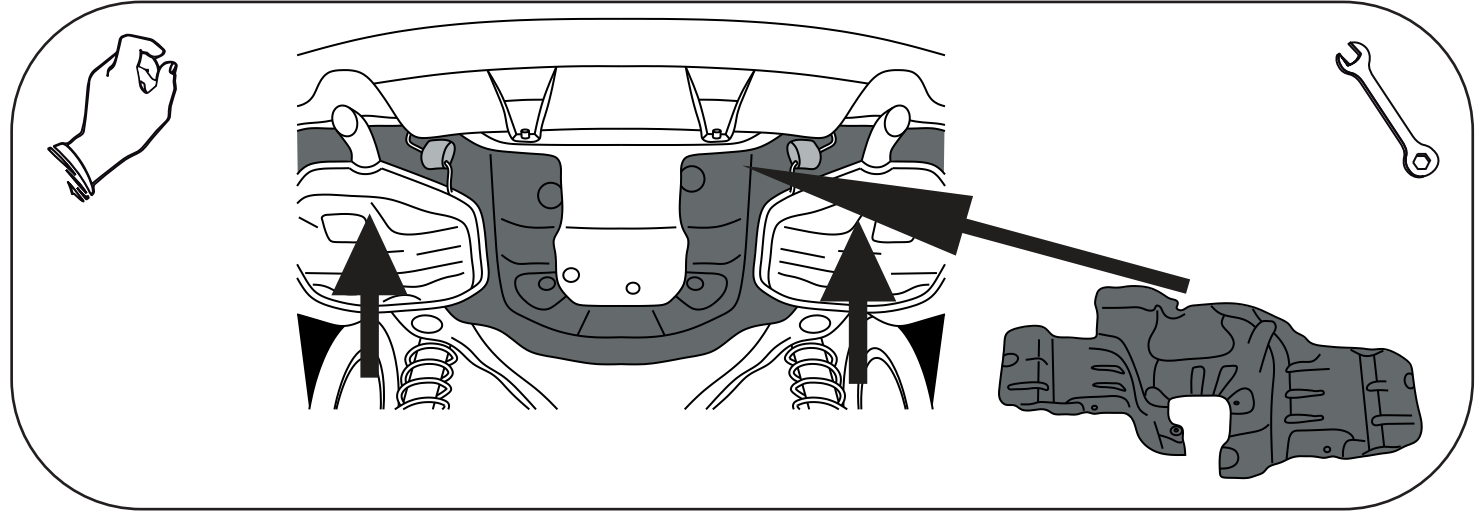
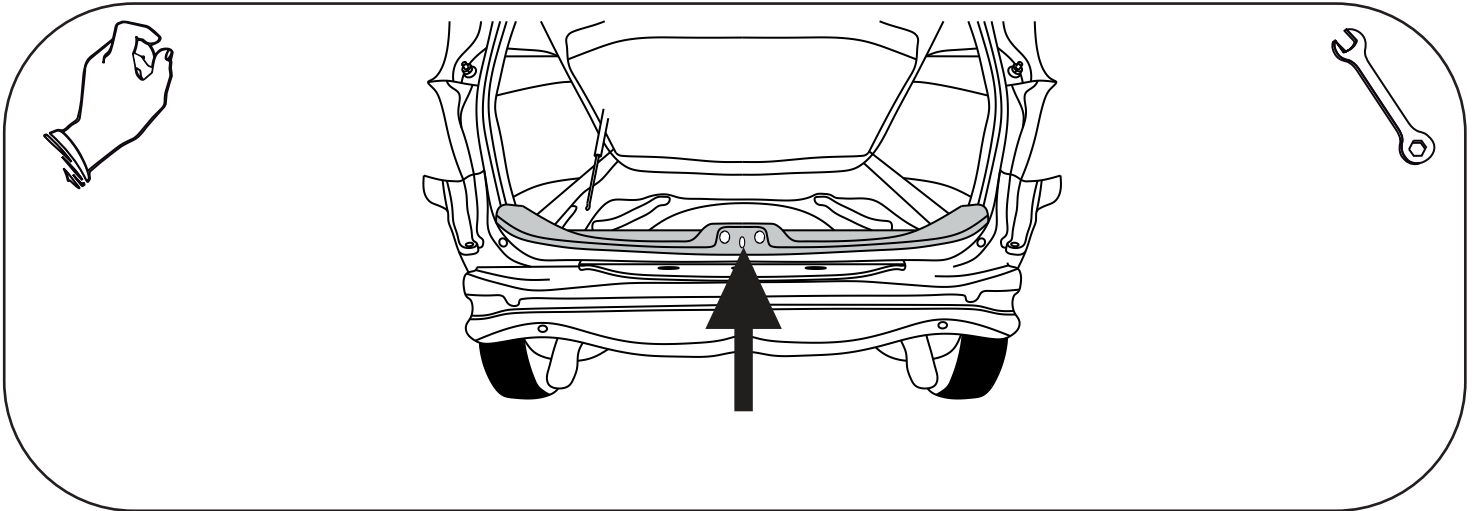
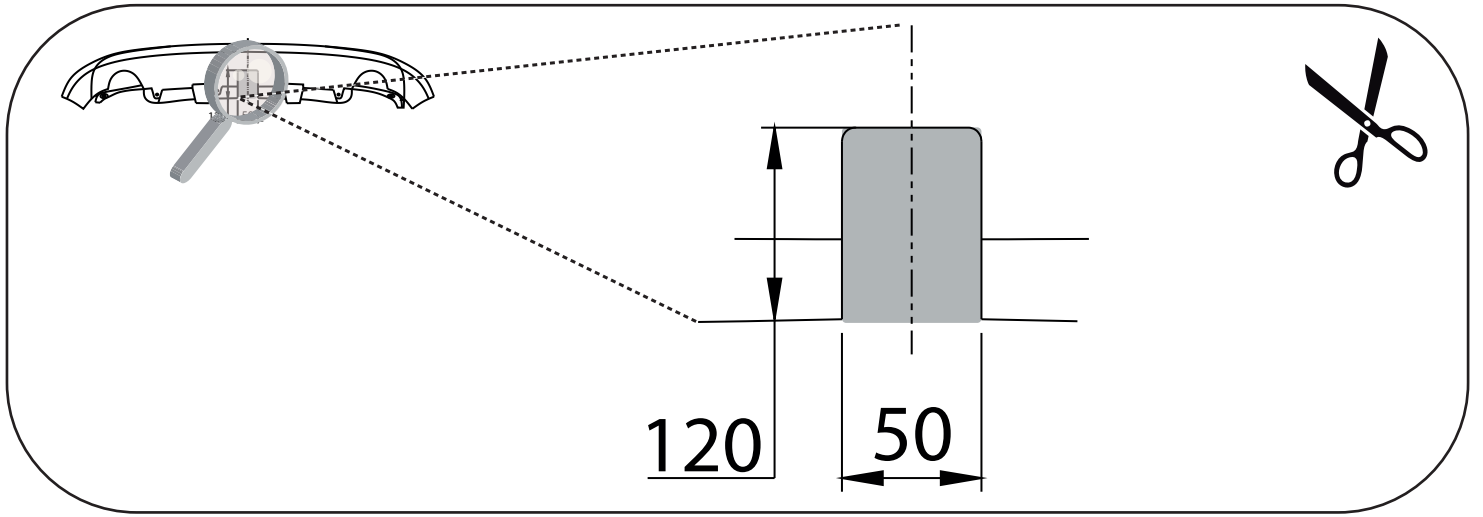

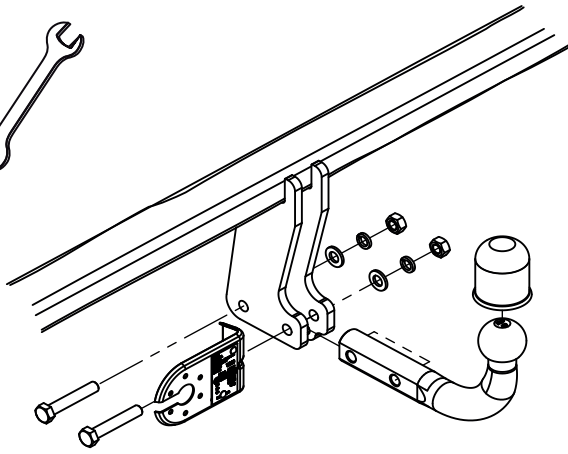
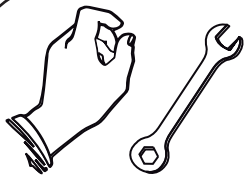

M12x70 x2



12,2 x2



13 x2

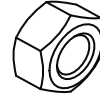

M12 x2