



Cat. No. **Z/013**

SKODA SUPERB II

2008-05/2015

SKODA SUPERB II estate

2010-05/2015

e20

e20 \*94/20\*1387\*00

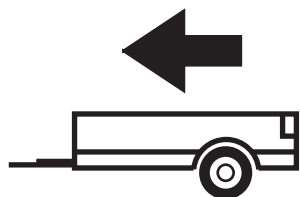

1800kg



75kg

**D** = 9,58kN

**D (kN) =**



MAX kg

x

MAX kg

x 0,00981



MAX kg

+

MAX kg

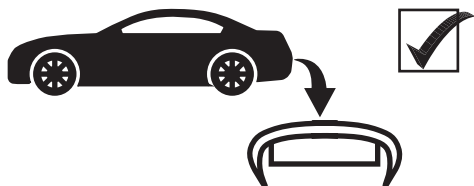

IMIOLA HAK-POL

96-111 KOWIESY, CHOJNATA 23A, POLAND

Tel. + 48 46 831 73 31, fax +48 831 74 29

e-mail: office@imiola.pl, www.imiola.pl

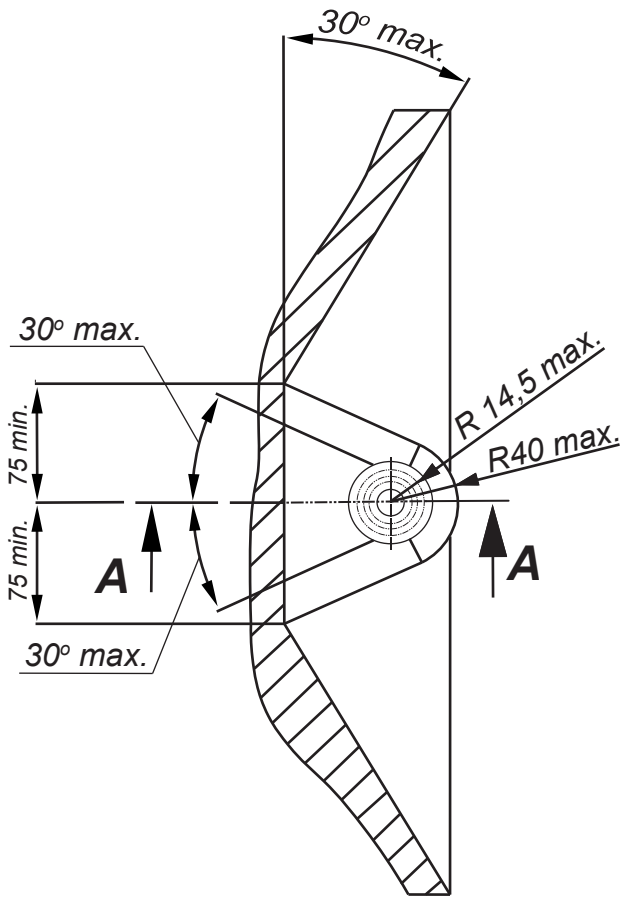

## PRZEKRÓJ A-A

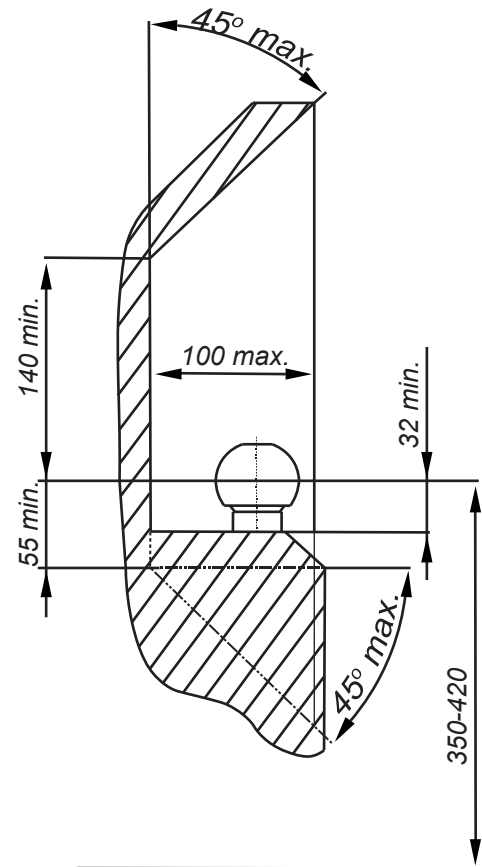

**PL** Należy zagwarantować przestrzeń swobodną według załącznika VII, rysunek 25a/b Regulaminu EKG ONZ 55.01 przy dopuszczalnym ciężarze całkowitym pojazdu.

**F** L'espace libre doit être garanti conformément à l'annexe VII, illustration de la réglementation 55.01 CE pour un poids total en charge autorisé du véhicule.





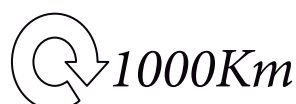

**GB** The clearance specified in appendix VII, diagram 25a/b of Regulation No. 55.01 UN EU must be guaranteed at laden weight of the vehicle.

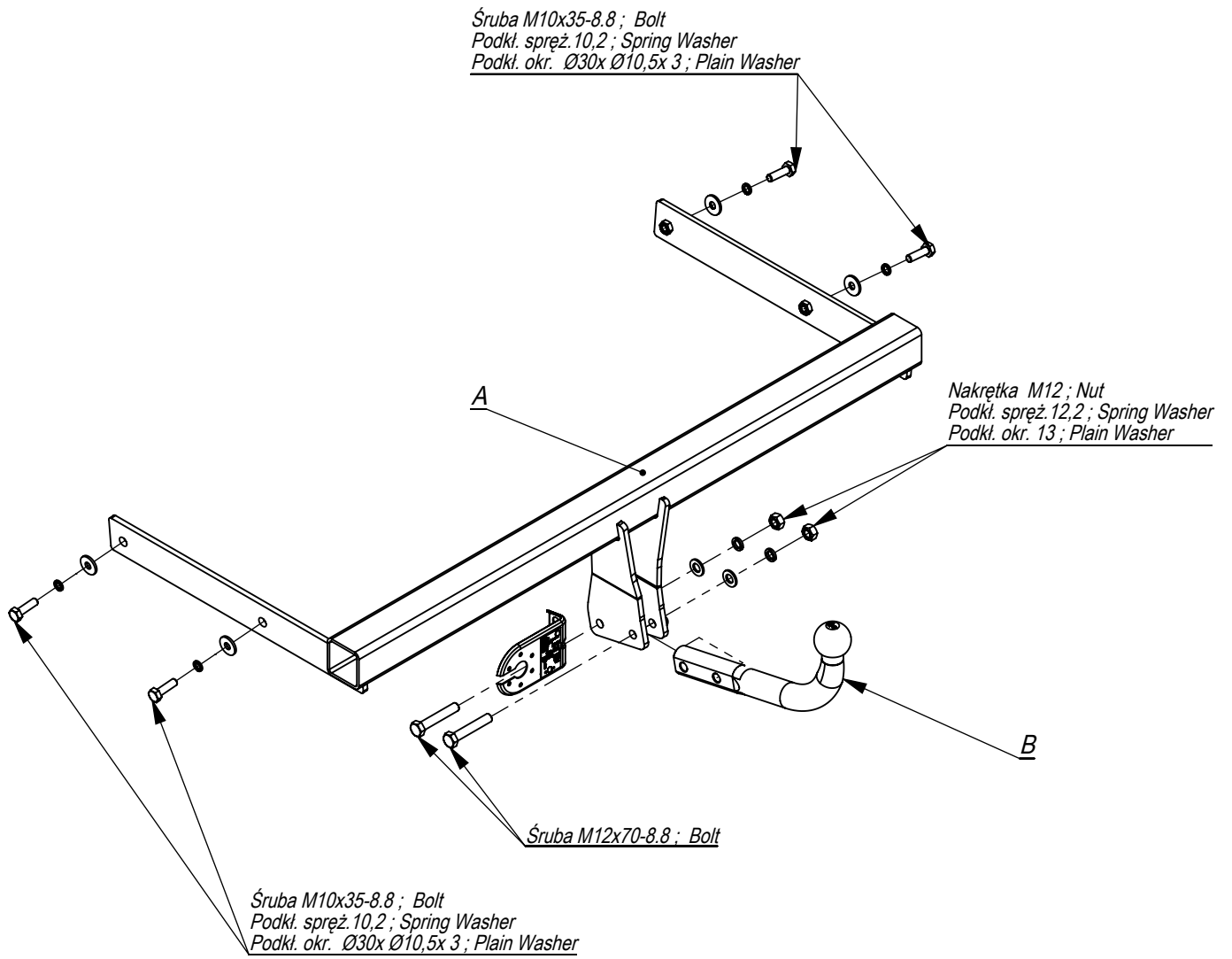
**D** Der Freiraum nach Anhang VII, Abbildung 25a/b der Vorschriften 55.01 EG ist zu gewährleisten bei zulässigem Gesamtgewicht des Fahrzeuges.

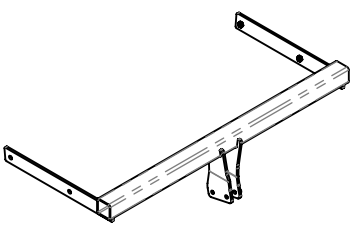
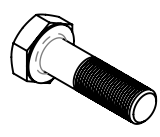
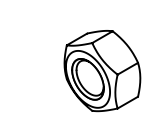
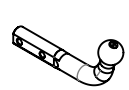
Moment skręcający dla śrub i nakrętek (8.8) Torque settings for nuts and bolts (8.8)	
M8	25Nm
M10	55Nm
M12	85Nm
M14	135Nm
M16	195Nm





	A	x1		M12x70	2
				M10x35	4
	B	x1		M12	2
	C	x1		Ø30xØ10,5x3	4
				13	2
				12,2	2
				10,2	4

Śruba M10x35-8.8 ; Bolt  
 Podki. spręż. 10,2 ; Spring Washer  
 Podki. okr. Ø30x Ø10,5x 3 ; Plain Washer

Nakrętka M12 ; Nut  
 Podki. spręż. 12,2 ; Spring Washer  
 Podki. okr. 13 ; Plain Washer

Śruba M10x35-8.8 ; Bolt  
 Podki. spręż. 10,2 ; Spring Washer  
 Podki. okr. Ø30x Ø10,5x 3 ; Plain Washer

Śruba M12x70-8.8 ; Bolt

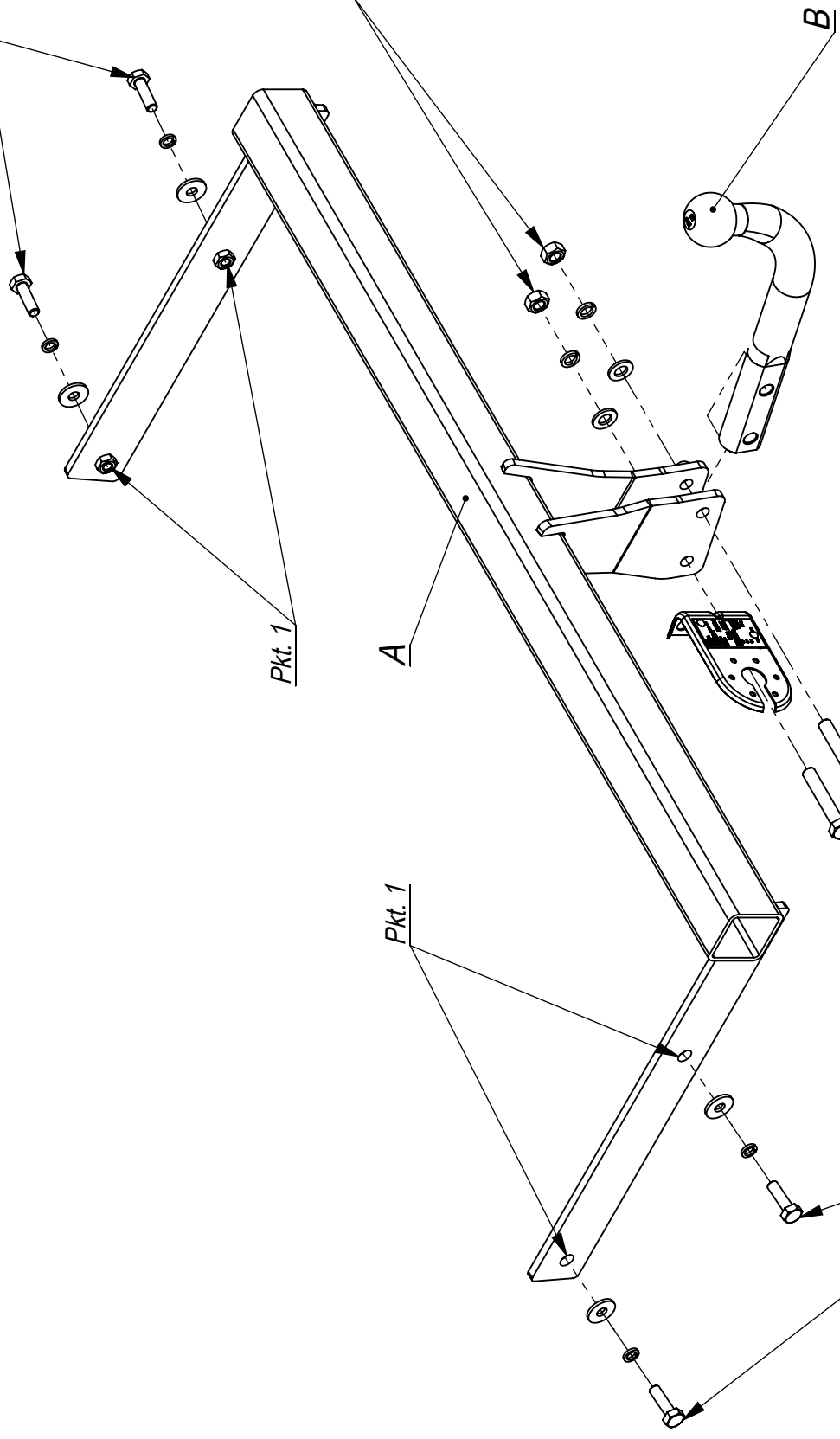

96-111 Kowiesy, Chojnata 23 A  
 tel. +48 46 831 73 31

Marka  
 Skoda Superb od 2008 ->  
 Skoda Superb combi od 2010 ->

Nr katalogowy  
 Z1013

- Odkręcić zderzak i belkę zderzeniową ( nie będzie już wykorzystana) .
- Belkę haka A wsunąć do podłużnic i przykręcić śrubami M10x40 8.8 (pkt 1 i 2 ) wykorzystując odpowiednie otwory .
- Wykonać wycięcie w osi, w dolnej części zderzaka na uchwyty kuli.
- Zamontować zderzak i.
- Dokręcić wszystkie śruby z momentem według tabeli.
- Dokręcić kulę i blachę gniazda elektrycznego.
- Podłączyć instalację elektryczną.

- Unscrew the bumper and bumper bar (it will not be used any more).
- Insert the main bar A between the frame side members and screw with bolts M10x40 8.8 (point 1 and 2) using the appropriate holes.
- Cut out the fragment in the lower part of the bumper for towball handles.
- Assemble the bumper.
- Tighten all the bolts according to the torque setting- see the table.
- Fix the ball and electric plate.
- Connect the electric wires.

- Dévisser le pare-chocs et le renforcement de pare-chocs (il ne sera plus utilisé).
- Placer la barre a crochet A sur les longerons du châssis et la fixer avec les vis M10x40 8.8 (point 1,2 ) en utilisant les trous appropriés.
- Exécuter une encoche dans la partie inférieure du pare-chocs, pour les encastresments de la boule.
- Installer le pare-chocs
- Serrer tous les boulons avec un couple de serrage selon tableau.
- Visser la boule et la tôle de la prise électrique.
- Brancher l'installation électrique

- Schrauben Sie den Stoßfänger
- Schrauben Sie die Stoßstange ab (sie wird nicht mehr verwendet).
- Die Löcher an den Seiten der Metallklammern machen durchlässig (diese Löcher sind verklebt).
- Setzen Sie die Seitenelemente der Hauptleiste in die Metallklammern ein und schrauben Sie sie mit den Schrauben M10x40 8.8 fest (Punkt 1 und 2).
- Einen Ausschnitt im unteren Teil der Stoßstange, in ihrer Achse.
- Ziehen Sie alle Schrauben entsprechend der Drehmomenteinstellung fest - siehe Tabelle.
- Schrauben Sie den Stoßfänger fest.
- Befestigen Sie den Ball und die elektrische Platte.
- Schließen Sie die elektrischen Kabel an.

- Desmontar el parachoques.
- Desmontar la barra del parachoques (ya no será necesaria)
- Limpiar los orificios de fábrica en el chasis.
- Apretar la barra del gancho A com tornillos M10x40 8.8 (punto 1 y 2).
- Cortar la parte inferior del parachoques, en su eje, para una abertura para el soporte del balón.
- Montar el parachoques,
- Apretar todos los tornillos con el par según la tabla anterior.
- Apretar la bola y la placa de la toma eléctrica.
- Conectar la instalación eléctrica.

