



Skoda Octavia sed., com., RS, Scout
 VW Golf, GTI, Sportsvan
 Audi A3, limousine, Sportback, Cabrio, S-lin, Q2 S-line, Q2
 Seat Leon, SC, FR, SC FR, SC FR Edit., X-PERIENCE, ST, ST FR

2013 -
 2012 -
 2012 -
 2013 -

Cat. No.: Z/A16

E20 55R02/00*006180*00

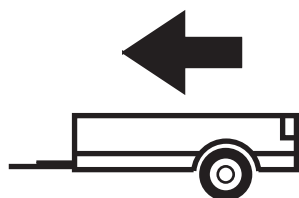

2000kg

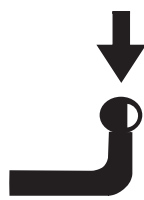

100kg

D = 10,00kN

$$D \text{ (kN)} = \frac{\text{MAX kg} \times \text{MAX kg}}{\text{MAX kg} + \text{MAX kg}} \times 0,00981$$

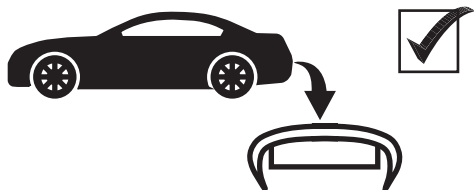

IMIOLA HAK-POL

96-111 KOWIESY, CHOJNATA 23A, POLAND

tel. +48 46 831 73 31, fax +48 831 74 29

e-mail: office@imiola.pl, www.imiola.pl

Rys. 25a

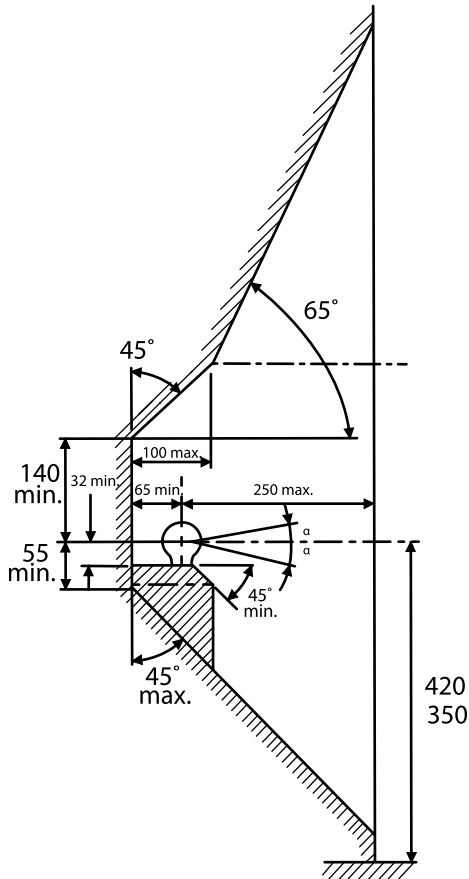

Rys. 25b

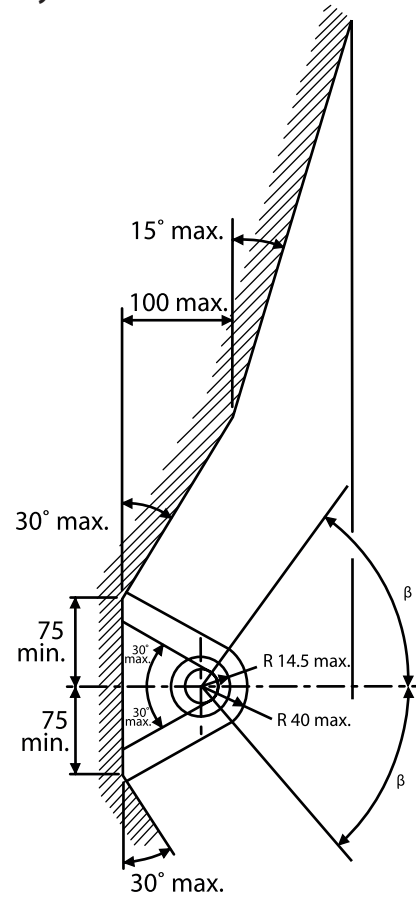

PL Należy zagwarantować przestrzeń swobodną według załącznika VII, rysunek 25a/b Regulaminu ONZ 55.02 przy dopuszczalnym ciężarze całkowitym pojazdu.

FR L'espace libre doit être garanti conformément à l'annexe VII, illustration de la réglementation 55.02 CE pour un poids total en charge autorisé du véhicule.





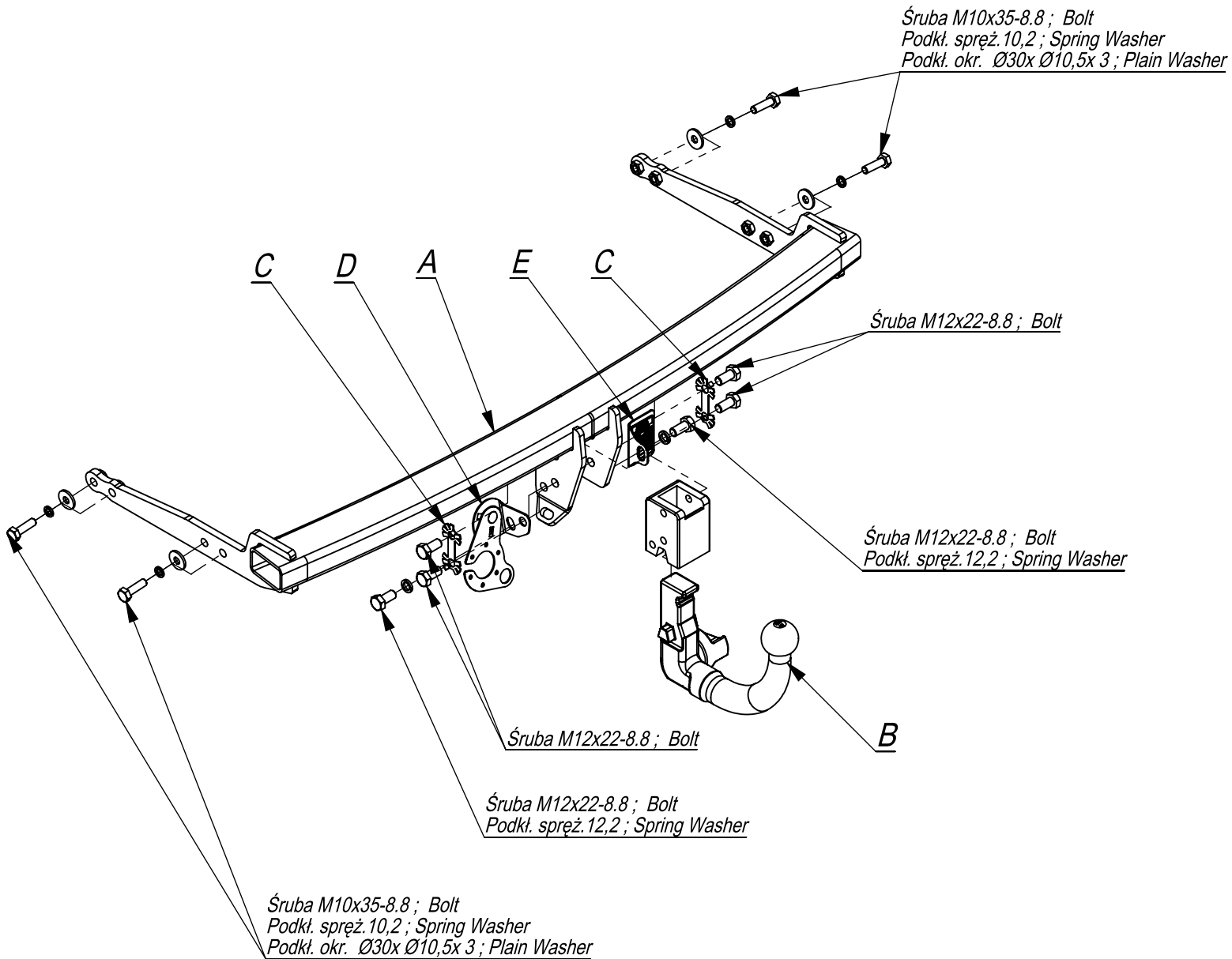

GB The clearance specified in appendix VII, diagram 25a/b of UN Regulation No. 55.02 must be guaranteed at laden weight of the vehicle.

DE Der Freiraum nach Anhang VII, Abbildung 25a/b der Vorschriften 55.02 EG ist zu gew 25a/bahrleisten bei zulässigem Gesamtgewicht des Fahrzeuges.

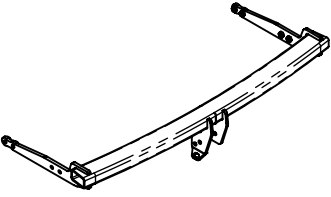
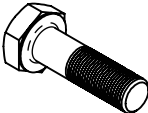
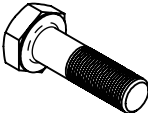
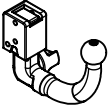
Moment skręcający dla śrub i nakrętek (8.8) Torgue settings for nuts and bolts (8.8)	
M8	25Nm
M10	55Nm
M12	85Nm
M14	135Nm
M16	195Nm





	A	x1		M12x22	6
				M10x35	4
	B	x1		Ø30xØ10,5x3	4
				12,2	2
	C	x2		10,2	4
				D	x1
	E	x1			

Pkt. 1:
 Audi A3 Sportback 2012->
 Audi A3 Cabrio S-line 2014->
 Skoda Octavia 2013->
 Skoda Octavia RS 2013->
 Skoda Octavia Combi 2013->
 Skoda Octavia Combi RS 2013->
 Skoda Octavia Scout 2014->

Pkt. 1:
 Audi A3 Sportback 2012->
 Audi A3 Cabrio S-line 2014->
 Skoda Octavia 2013->
 Skoda Octavia RS 2013->
 Skoda Octavia Combi 2013->
 Skoda Octavia Combi RS 2013->
 Skoda Octavia Scout 2014->

Pkt. 2:
 Audi A3 2012->
 Audi A3 Limusine 2014->
 Audi A3 Cabrio 2014->
 Seat Leon 2013->
 Seat Leon SC 2013->
 Seat Leon ST 2013->
 Seat Leon ST FR 2013->
 Seat Leon X-Perience 2014->
 VW Golf 2012->
 VW Golf GTI 2013->
 VW Golf Sportsvan 2014->

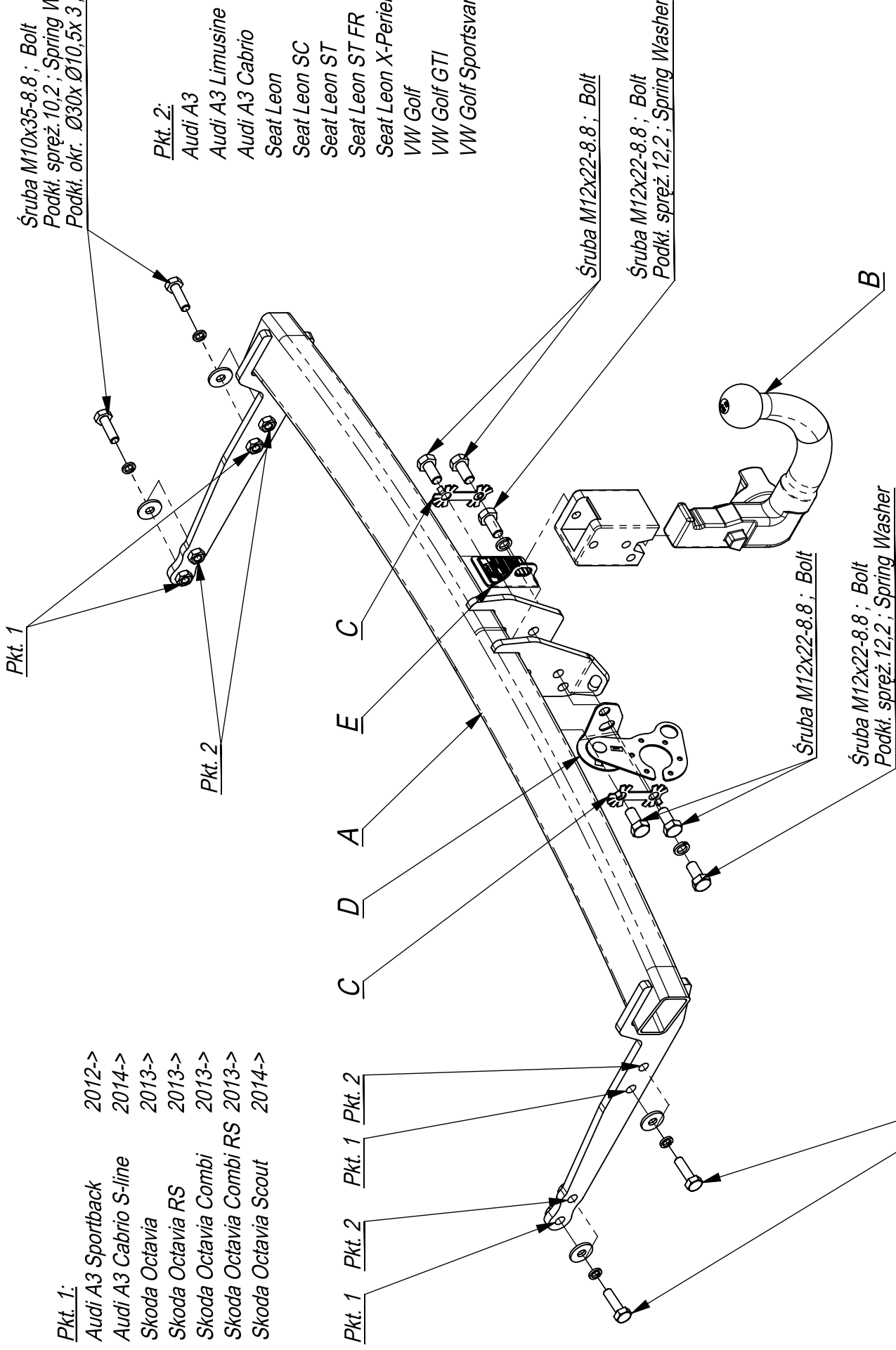

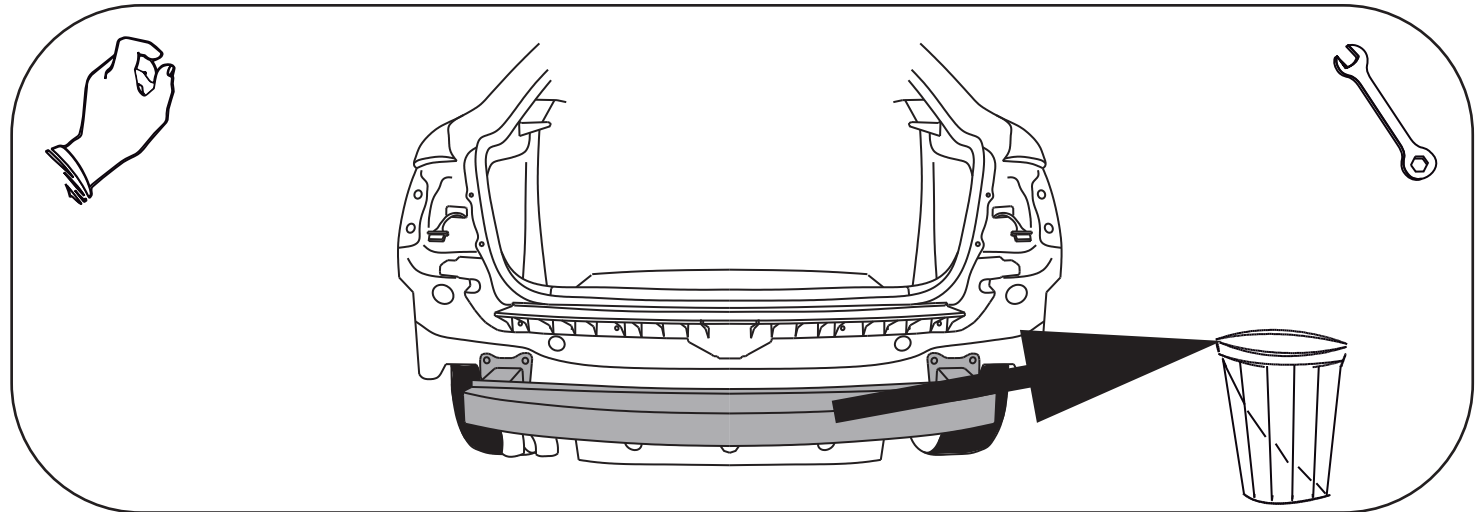
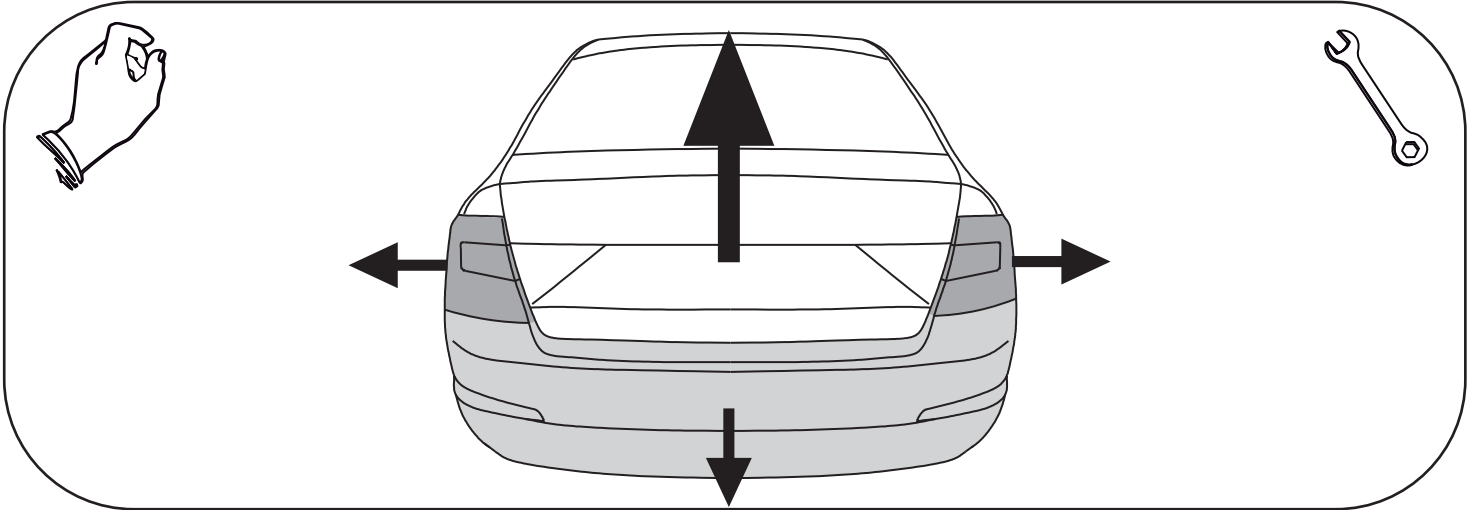
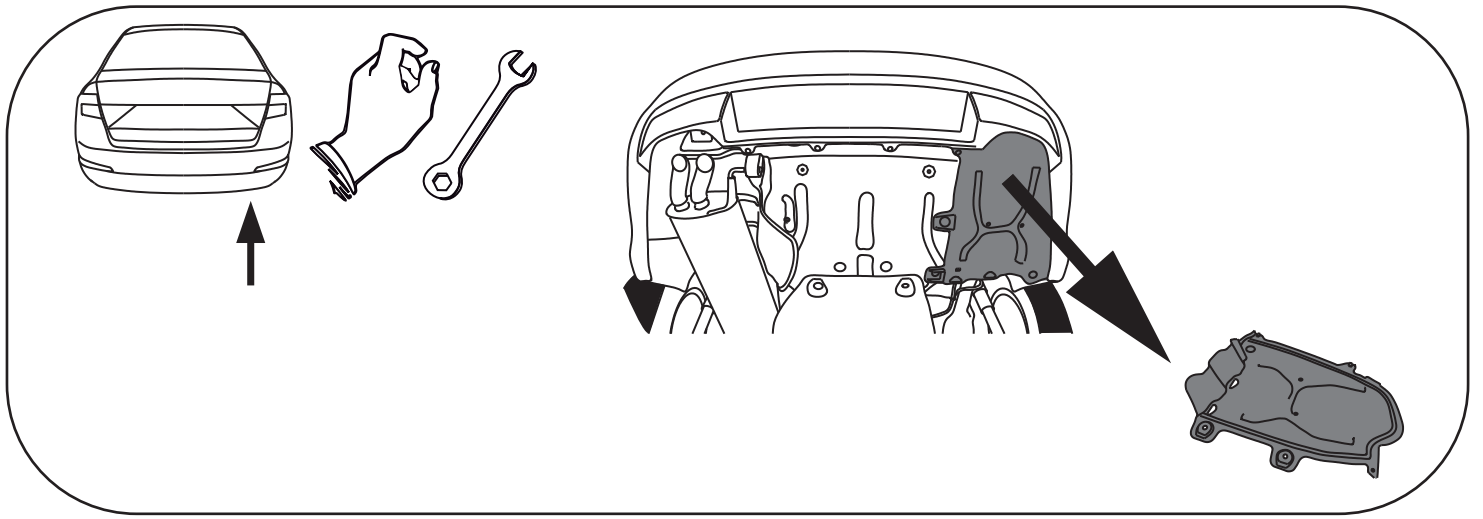

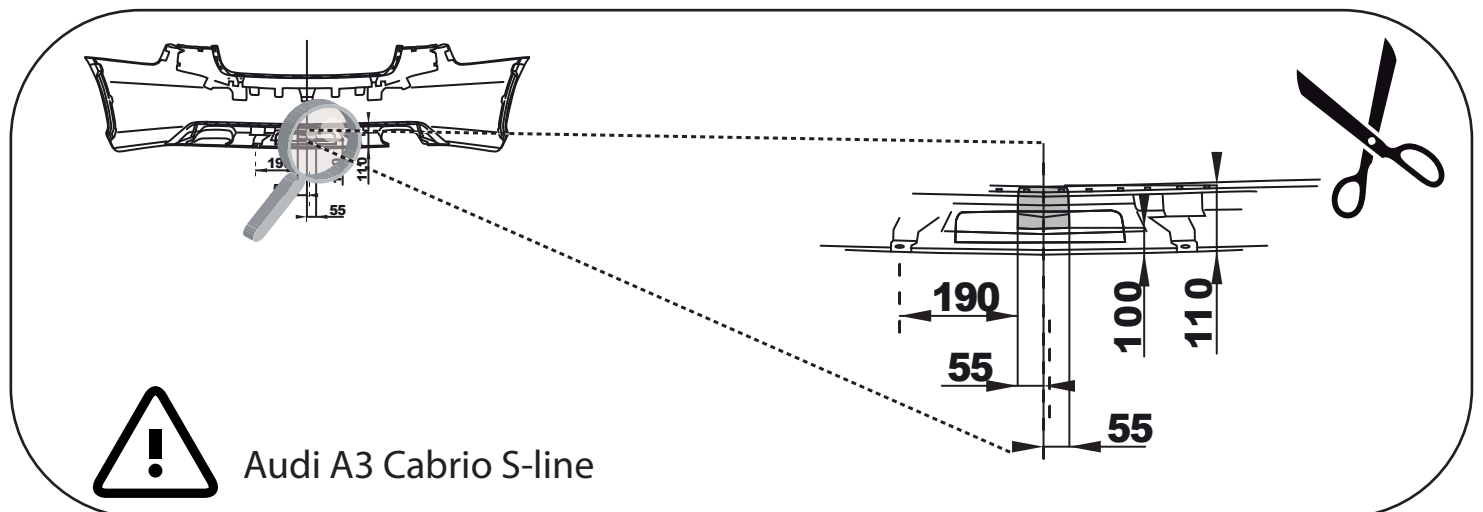
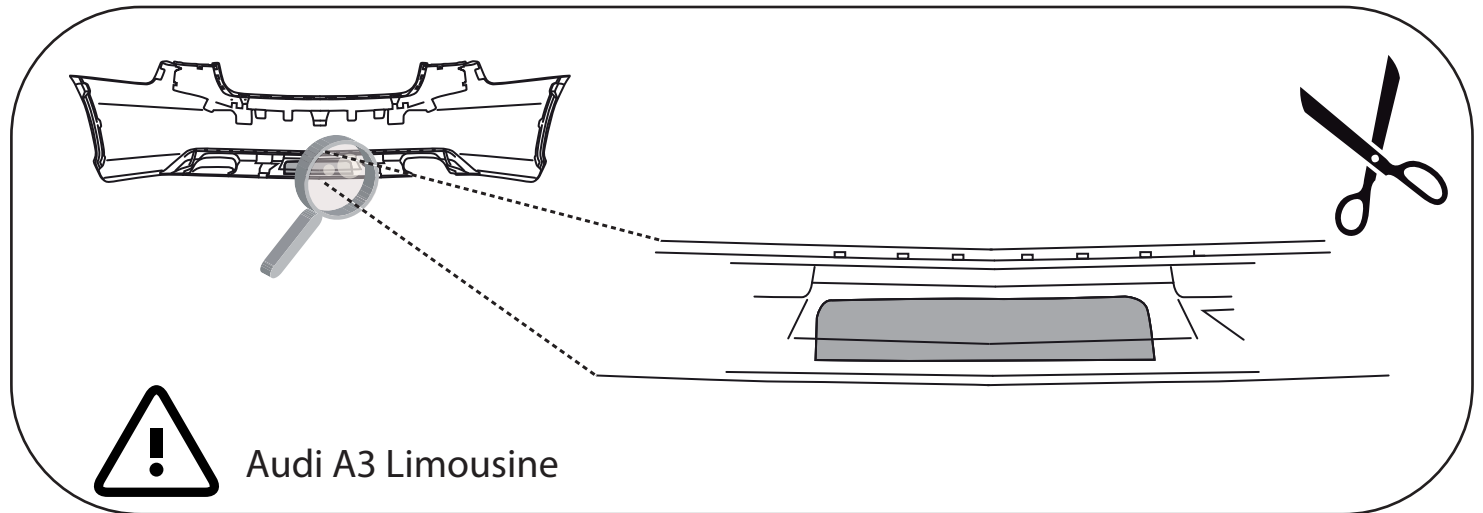
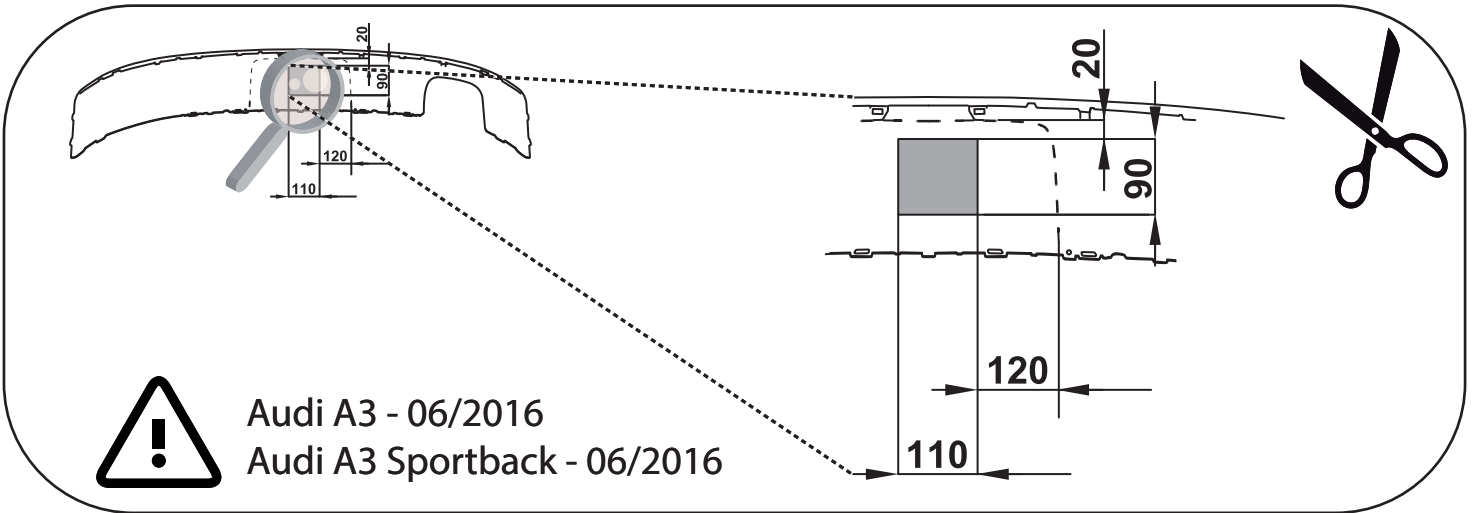
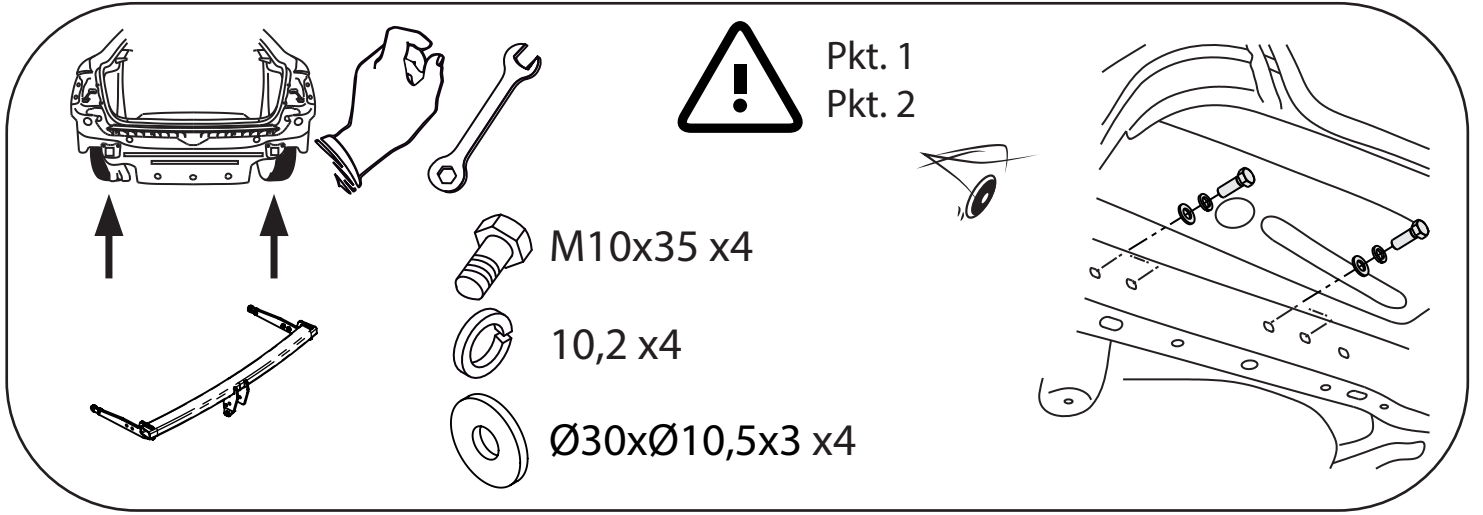

! Audi A3 Cabrio

! Seat Leon
Seat Leon SC

! Seat Leon FR
Seat Leon SC FR

! Seat Leon SC FR Edition

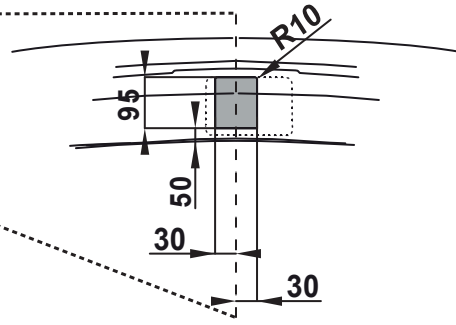
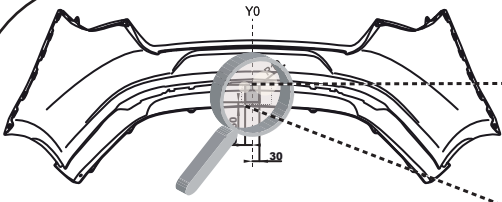

Seat Leon ST

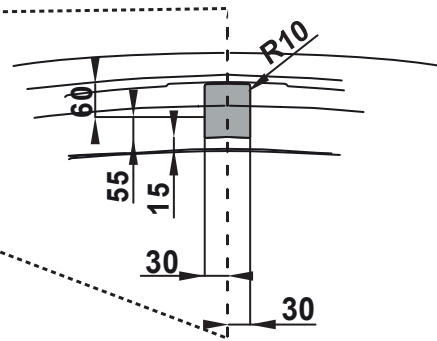
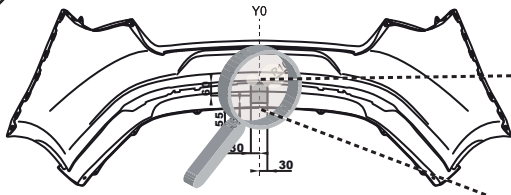

Seat Leon ST FR

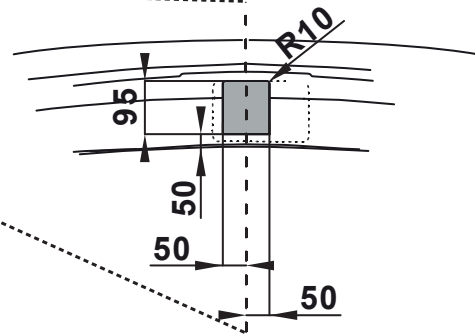
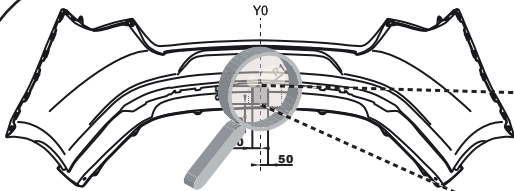

Seat Leon X-PERIENCE

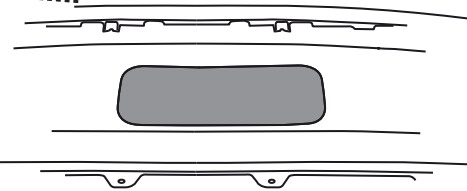
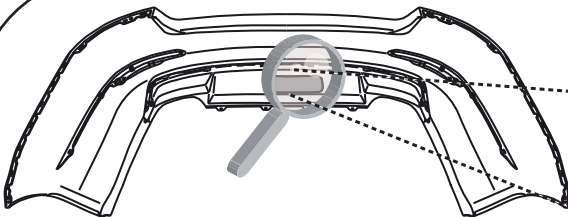

Skoda Octavia
Skoda Octavia Combi
Skoda Octavia RS
Skoda Octavia Combi RS
Skoda Octavia Scout

